

Temposonics®

Magnetostrictive, Absolute, Non-contact
Linear-Position Sensors

E-Series Model EP2
Analog (Voltage) Output

Data Sheet



Document Part Number
550919 Revision E



**Model EP2 Profile-style position sensor
with single-position measurement**

FEATURES

- Linear, Absolute Measurement
- Non-Contact Sensing Technology
- Linearity Deviation Less Than 0.03%
- Repeatability Within 0.005%
- Direct Position Output: Analog 0 - 10 Vdc
- Magnet is Secured to Moving Machine Part to 'Float' over the Sensor Housing
- One Year Warranty

BENEFITS

- Economically Priced Magnetostrictive Sensor Technology
- EMI Shielded and CE Certified
- Factory Set Null And Span Setpoints
- Sensors Can Be Purchased Factory Direct From The MTS *Online Store*

APPLICATIONS

- Continuous Operation in Harsh Industrial Conditions
- Plastic Injection and Blow Molding
- Product Fabrication and Assembly
- Cutting, Drilling, Punching, Pressing and Bending

TYPICAL INDUSTRIES

- Plastics Molding and Processing
- Material Handling and Packaging
- Factory Automation
- Woodworking and Metalworking

Time-based Magnetostrictive position sensing principle

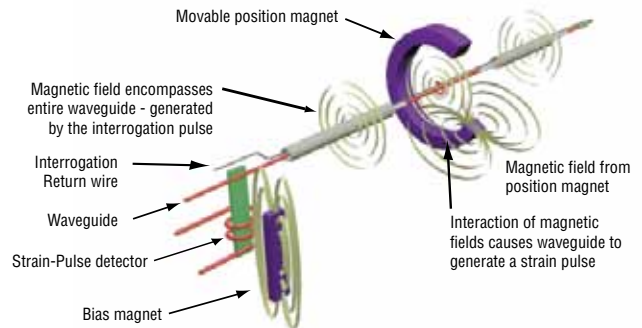

Benefits of Magnetostriction

Temposonics linear-position sensors use the time-based magnetostrictive position sensing principle developed by MTS. Within the sensing element, a sonic-strain pulse is induced in a specially designed magnetostrictive waveguide by the momentary interaction of two magnetic fields. One field comes from a movable permanent magnet that passes along the outside of the sensor. The other field comes from an "interrogation" current pulse applied along the waveguide. The resulting strain pulse travels at sonic speed along the waveguide and is detected at the head of the sensing element.

The position of the magnet is determined with high precision and speed by accurately measuring the elapsed time between the application of the interrogation pulse and the arrival of the resulting strain pulse with a high-speed counter. The elapsed time measurement is directly proportional to the position of the permanent magnet and is an absolute value. Therefore, the sensor's output signal corresponds to absolute position, instead of incremental, and never requires recalibration or re-homing after a power loss. Absolute, non-contact sensing eliminates wear, and guarantees the best durability and output repeatability.

All specifications are subject to change. Contact MTS for specifications and engineering drawings that are critical to your application. Drawings contained in this document are for reference only. Go to <http://www.mtssensors.com> for the latest support documentation and related media.

E-Series Model EP2 Sensor, Analog Output Product Overview and Specifications

Product overview

MTS Sensors continues to establish new performance standards for low-cost, fully-industrial, durable position sensors using the widely preferred magnetostrictive technology. This principle for accurate and non-contact measurement of linear-position sensing was developed 30 years ago by MTS and is used with outstanding success in a large variety of industrial applications.

The E-Series Model EP2 sensor with analog output can be ordered from the MTS [Online Store](http://www.mtssensorsstore.com) at <http://www.mtssensorsstore.com>

Product specifications

Parameters	Specifications
OUTPUT	
Measured output variable:	Position
Resolution:	Infinite, restricted by output ripple
Linearity deviation:	< ± 0.03% full stroke (minimum ± 90 µm)
Repeatability:	< ± 0.005% full stroke (minimum ± 2.5 µm)
Analog Output:	Voltage: 0 to 10 Vdc (Controller input resistance RL >5k ohms)
Position measurement:	Measurement Stroke lengths: 4, 6, 9, 12, 15, 18, 21, 24, 30, 36, 42, 48, 54 and 60 in. Contact factory for custom stroke lengths.
	Update Frequency: > 1.5 kHz
ELECTRONICS	
Operating voltage:	+24 Vdc nominal: -15% or +20% Polarity protection: up to -30 Vdc Overvoltage protection: up to 36 Vdc Current drain: 50 - 140 mA (Stroke length dependent) Dielectric withstand voltage: 500 Vdc (DC ground to machine ground)
ENVIRONMENTAL	
Operating conditions:	Operating temperature: -40 °C (-40 °F) to 75 °C (167 °F) Relative humidity: 90% no condensation
EMC test:	Emissions: IEC/EN 50081-1 Immunity: IEC/EN 50082-2 IEC/EN 61000-4-2/3/4/6, criterium A, CE qualified
Shock rating:	50 g (single hit)/ IEC standard 60068-2-27 (survivability)
Vibration rating:	5 g/10 to 2000 Hz, IEC standard 60068-2-6 (operational)
Wiring	
Connection type:	Integral cable
PROFILE STYLE SENSOR (MODEL EP2)	
Sealing:	IP 67
Sensor extrusion:	Aluminum
Mounting:	Any orientation. Adjustable mounting feet.
Magnet type:	Block magnet with stamped metal carrier

E-Series Model EP2 Sensor, Analog Output Output, Sensor Dimensions and Magnet References

Output

The Temposonics E-Series Model EP2 analog output sensor comes standard with integrated analog conditioning electronics. The sensor can be connected to a control system or indicator directly without the need for an additional interface. Built-in microelectronics produce a continuous voltage output that is proportional to the magnet position. The active measurement stroke range is factory set (see 'Figure 1').

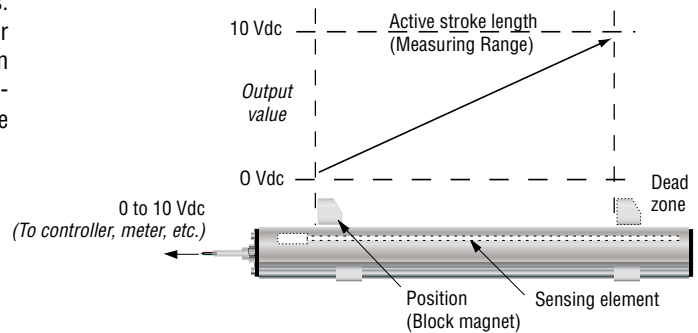

Figure 1. Active stroke length (measuring range)

Model EP2 profile-style sensor (analog output) dimension references

Model EP2, profile-style sensor with Block, Style L Magnet

Drawing is for reference only, contact applications engineering for tolerance specific information.

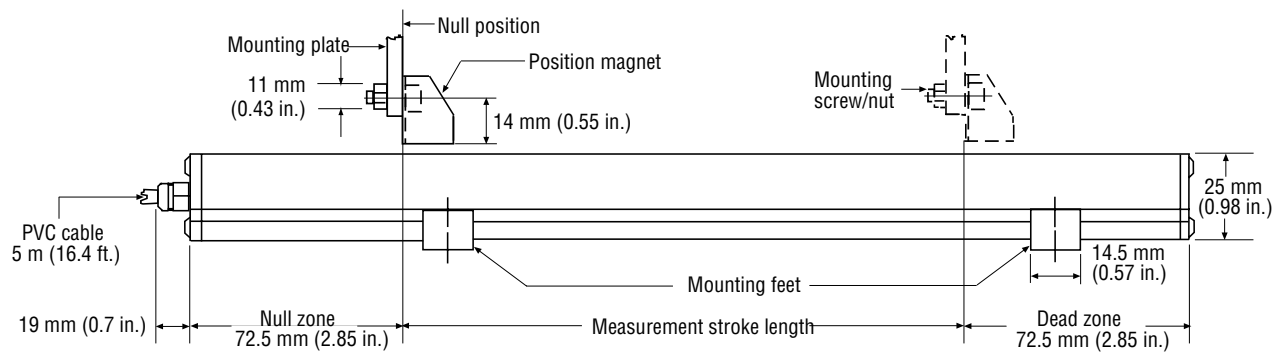



Figure 2. E-Series Model RP Profile-style sensor dimension reference (Shown with 5 m (16.4 ft.) integral cable)

Standard magnet (Model EP2)

One Block magnet included with Model EP2 sensor

The *Style L 'block'* magnet (part no.: 252887) mounts on the moving machine part and travels just above the sensor's extrusion. The magnet can be mounted using ferrous metal screws on a mounting plate (customer supplied) or flat surface of the machine's moving part. The mounting plate or machine part can not extend beyond 11 mm (0.43 in.) from the top of the magnet, unless it is made of non-ferrous material. The magnet should be installed in a perpendicular orientation relative to the top surface of the sensor extrusion (see 'Figure 2'). Optimal performance is achieved when this orientation remains consistent throughout the full measurement stroke range.

BLOCK MAGNET, STYLE L (One Magnet included with each Model EP2 sensor) *(Drawing dimensions are for reference only)*

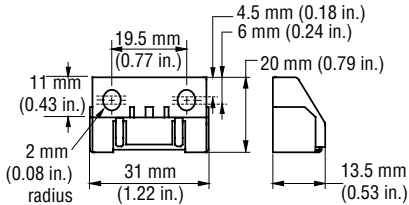
Magnet and mounted magnet dimensions	Description	Part number
 	<p>Block magnet, Style L For Model EP2 profile-style sensor</p>	252887

E-Series Model EP2 Sensor, Analog Output Mounting and Wiring

Sensor mounting

MODEL EP2 SENSOR MOUNTING

Temposonics model EP2 profile-style sensors are mounted onto a flat straight surface of the machine with moveable mounting feet. A pair (2) mounting feet are provided with each sensor. Two additional mounting feet (part no. 400802) are included for measurement stroke lengths greater than 48 inches. Mounting feet slide into side grooves and should be evenly distributed along the sensor extrusion to best secure the sensor for each particular application.

Notes:

1. Additional mounting feet can be ordered separately.
2. MTS recommends using 10-32 cap screws (customer supplied) at a maximum torque of 44 in. lbs. when fastening mounting feet.

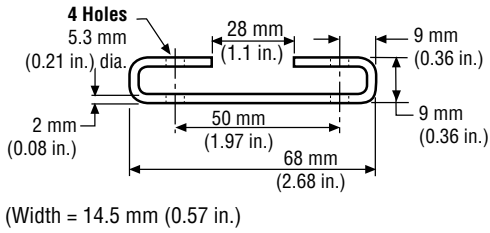
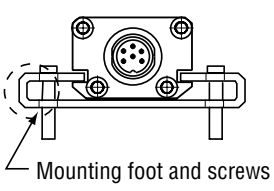
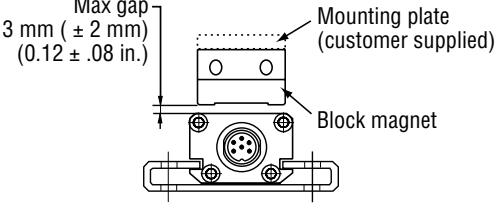
Profile-Style sensor mounting and installation reference	Mounting method	Part number
  <p>(Width = 14.5 mm (0.57 in.))</p>	<p>Mounting feet, standard (304 SS)</p> <p>Profile-style sensor mounting for sensor model EP2</p>	400802
 <p>Mounting foot and screws</p>  <p>Max gap 3 mm (± 2 mm) (0.12 ± .08 in.)</p> <p>Mounting plate (customer supplied)</p> <p>Block magnet</p>	<p>Mounting feet and screws</p> <p>Profile-style sensor foot installation Secure mounting feet with customer supplied 10-32 Cap screws. (recommended)</p> <p>Block magnet, Style L mounting</p> <p>Magnet installs on a mounting plate (customer supplied) or flat surface of the machine's moving part.</p>	<p>Mounting feet, part number 400802</p> <p>Block magnet, style L part number 252887</p>

Wiring and integral cable connection

E-Series EP2 analog sensor - integral cable

The E-Series Model EP2 sensor connects directly to a controller, meter, etc. via 5 m (16.4 ft). PVC cable shown in 'Figure 3'. Wiring color and signal functions are described in 'Table 1'.



Figure 3. EP2 analog sensor Integral cable

Wire color	Signal
Green	0 to 10 Vdc
Brown	+24 Vdc (-15% / +20%)
White	DC Ground (0 Vdc)
Shield	Connected to sensor housing (Appropriate grounding of cable shield is required at the controller end).

Table 1. EP2 analog sensor cable wiring diagram

E-Series Model EP2 Sensor, Analog Output Ordering Information

Use the order matrix below to configure your Model EP2 analog sensor order number. Contact the factory for custom sensor orders.
E-Series Model EP2 sensors with analog output ordered can be purchased from the MTS **Online Store** at: <http://www.mtssensorsstore.com>

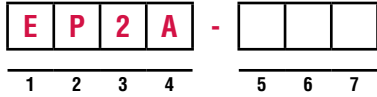

SENSOR MODEL _____ =

E	P	2	A
---	---	---	---

1 - 4

E-Series model EP2 sensor with analog output (voltage) and integral cable

____ = **MEASUREMENT STROKE LENGTH IN INCHES** _____ =

--	--	--

5 - 7

(Contact factory for custom stroke lengths)

- | | |
|--|---|
| <p>004 = 4 inch stroke length</p> <p>006 = 6 inch stroke length</p> <p>009 = 9 inch stroke length</p> <p>012 = 12 inch stroke length</p> <p>015 = 15 inch stroke length</p> <p>018 = 18 inch stroke length</p> <p>021 = 21 inch stroke length</p> | <p>024 = 24 inch stroke length</p> <p>030 = 30 inch stroke length</p> <p>036 = 36 inch stroke length</p> <p>042 = 42 inch stroke length</p> <p>048 = 48 inch stroke length</p> <p>054 = 54 inch stroke length</p> <p>060 = 60 inch stroke length</p> |
|--|---|



Document Part Number: 550919, Revision E 01/10, 08/11

MTS and Temposonics are registered trademarks of MTS Systems Corporation.

All other trademarks are the property of their respective owners.

Printed in USA. Copyright © 2011 MTS Systems Corporation. All Rights Reserved in all media.



**MTS Systems Corporation
Sensors Division**

3001 Sheldon Drive
Cary, North Carolina
27513, USA
Tel.: +1-800-633-7609
Fax: +1-919-677-2343
+1-800-498-4442
e-mail: sensorsinfo@mts.com
<http://www.mtssensors.com>

**MTS Sensor Technologie
GmbH & Co. KG**

Auf dem Schüffel 9
D - 58513 Lüdenscheid, Germany
Tel.: +49-2351-9587-0
Fax: +49-2351-56491
e-mail: info@mtssensor.de
<http://www.mtssensor.de>

**MTS Sensors Technology
Corporation**

737 Aihara-cho, Machida-shi
Tokyo 194-0211, Japan
Tel.: +81-42-775-3838
Fax: +81-42-775-5516
e-mail: info@mtssensor.co.jp
<http://www.mtssensor.co.jp>