

# Temposonics®

Magnetostrictive Linear Position Sensors

Temposonics® R-Series V Analog  
Operation Manual



**V**  
THE NEW GENERATION

## Table of contents

<b>1. Introduction</b>	<b>3</b>
1.1 Purpose and use of this manual	3
1.2 Used symbols and warnings	3
<b>2. Safety instructions</b>	<b>3</b>
2.1 Intended use	3
2.2 Foreseeable misuse	3
2.3 Installation, commissioning and operation	4
2.4 Safety instructions for use in explosion-hazardous areas	4
2.5 Warranty	4
2.6 Return	4
<b>3. Identification</b>	<b>5</b>
3.1 Order code of Temposonics® RP5	5
3.2 Order code of Temposonics® RH5	7
3.3 Nameplate	9
3.4 Approvals	9
3.5 Scope of delivery	9
<b>4. Product description and commissioning</b>	<b>10</b>
4.1 Functionality and system design	10
4.2 Styles and installation of Temposonics® RP5	11
4.3 Styles and installation of Temposonics® RH5	12
4.4 Magnet installation	15
4.5 Replacement of base unit	17
4.6 Electrical connections	18
4.7 Frequently ordered accessories for RP5 design	19
4.8 Frequently ordered accessories for RH5 design	20
4.9 Frequently ordered accessories for Analog output	21
<b>5. Programming</b>	<b>23</b>
5.1 Analog Output Options	23
5.2 Introduction	23
5.3 LED Status	24
5.4 Programming via MTS Sensors service tools	25
5.5 Programming and configuration	27
<b>6. Maintenance and troubleshooting</b>	<b>34</b>
6.1 Error conditions, troubleshooting	34
6.2 Maintenance	34
6.3 Repair	34
6.4 List of spare parts	34
6.5 Transport and storage	34
<b>7. Removal from service / dismantling</b>	<b>34</b>
<b>8. Technical data</b>	<b>35</b>
8.1 Technical data Temposonics® RP5	35
8.2 Technical data Temposonics® RH5	36
<b>9. Appendix I</b>	<b>37</b>
<b>10. Appendix II</b>	<b>38</b>
<b>11. Glossary</b>	<b>39</b>

## 1. Introduction

### 1.1 Purpose and use of this manual

Before starting the operation of Temposonics® position sensors, read this documentation thoroughly and follow the safety information. Keep this manual for future reference!

The content of this technical documentation and of its appendices is intended to provide information on mounting, installation and commissioning by qualified automation personnel <sup>1</sup> or instructed service technicians who are familiar with the project planning and dealing with Temposonics® sensors.

### 1.2 Used symbols and warnings

Warnings are intended for your personal safety and for avoidance of damage to the described product or connected devices. In this documentation, safety information and warnings to avoid danger that might affect the life and health of operating or service personnel or cause material damage are highlighted by the pictogram defined below.

Symbol	Meaning
<b>NOTICE</b>	This symbol is used to point to situations that may lead to material damage, but not to personal injury.

## 2. Safety instructions

### 2.1 Intended use

This product may be used only for the applications defined under item 1 and only in conjunction with the third-party devices and components recommended or approved by MTS Sensors. As a prerequisite of proper and safe operation the product requires correct transport, storage, mounting and commissioning and must be operated with utmost care.

- The sensor systems of all Temposonics® series are intended exclusively for measurement tasks encountered in industrial, commercial and laboratory applications. The sensors are considered as system accessories and must be connected to suitable evaluation electronics, e.g. a PLC, IPC, indicator or other electronic control unit.

<sup>1/</sup> The term "qualified technical personnel" characterizes persons who:

- are familiar with the safety concepts of automation technology applicable to the particular project

### 2.2 Foreseeable misuse

Foreseeable misuse	Consequence
Wrong sensor connection	The sensor will not work properly or can be damaged
Operate the sensor out of the operating temperature range	No signal output – the sensor can be damaged
Power supply is out of the defined range	Signal output is wrong/ no signal output/ the sensor will be damaged
Position measurement is influenced by an external magnetic field	Signal output is wrong
Cables are damaged	Short circuit – the sensor can be damaged/sensor does not respond
Spacers are missing/ installed in a wrong order	Error in position measurement
Wrong connection of ground/shield	Signal output is disturbed – the electronics can be damaged
Use of a magnet that is not specified by MTS Sensors	Error in position measurement

**Do not alter the sensor afterwards.**  
→ The sensor might be damaged.

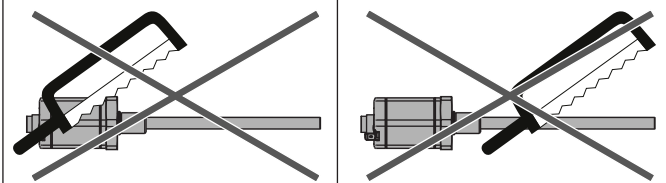

**Do not step on the sensor.**  
→ The sensor might be damaged.

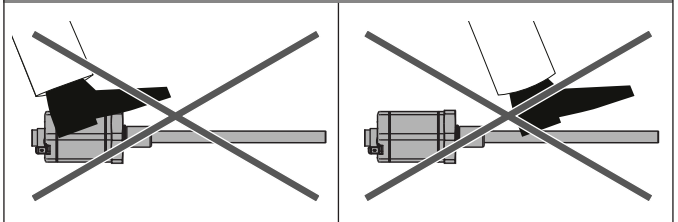

- are competent in the field of electromagnetic compatibility (EMC)
- have received adequate training for commissioning and service operations
- are familiar with the operation of the device and know the information required for correct operation provided in the product documentation

## 2.3 Installation, commissioning and operation

The position sensors must be used only in technically safe conditions. To maintain this condition and to ensure safe operation, installation, connection and service, work may be performed only by qualified technical personnel.

If danger of injury to persons or of damage to operating equipment is caused by sensor failure or malfunction, additional safety measures such as plausibility checks, limit switches, EMERGENCY STOP systems, protective devices etc. are required. In the event of trouble, shut down the sensor and protect it against accidental operation.

### Safety instructions for commissioning

To maintain the sensor's operability, it is mandatory to follow the instructions given below.

1. Protect the sensor against mechanical damage during installation and operation.
2. Do not open or dismantle the sensor.
3. Connect the sensor very carefully and pay attention to the polarity of connections and power supply.
4. Use only approved power supplies.
5. Ensure the sensor is operating within the defined limits for supply voltage, environmental conditions, etc.
6. Check the function of the sensor regularly and provide documentation of the checks.
7. Before applying power, ensure that nobody's safety is jeopardized by starting machines.

## 2.4 Safety instructions for use in explosion-hazardous areas

The sensor is not suitable for operation in explosion-hazardous areas.

## 2.5 Warranty

MTS Sensors grants a warranty period for the Temposonics® position sensors and supplied accessories relating to material defects and faults that occur despite correct use in accordance with the intended application<sup>2</sup>. The MTS Sensors obligation is limited to repair or replacement of any defective part of the unit. No warranty can be provided for defects that are due to improper use or above average stress of the product, as well as for wear parts. Under no circumstances will MTS Sensors accept liability in the event of offense against the warranty rules, no matter if these have been assured or expected, even in case of fault or negligence of the company. MTS Sensors explicitly excludes any further warranties. Neither the company's representatives, agents, dealers nor employees are authorized to increase or change the scope of warranty.

## 2.6 Return

For diagnostic purposes, the sensor can be returned to MTS Sensors or a repair facility explicitly authorized by MTS Sensors. Any shipment cost is the responsibility of the sender<sup>2</sup>. For a corresponding form, see chapter "9. Appendix I" on page 37.

### NOTICE

When returning sensors, place protective caps on male and female connectors of the sensor. For pigtail cables, place the cable ends in a static shielding bag for electrostatic discharge (ESD) protection. Fill the outer packaging around the sensor completely to prevent damage during transport.

<sup>2/</sup> See also applicable MTS Sensors terms of sales and delivery on:  
[www.mtssensors.com](http://www.mtssensors.com)

### 3. Identification

#### 3.1 Order code of Temposonics® RP5

1	2	3	4	5	6	7	8	9	10	11	12	13	14	15	16	17	18	19	20	21	22	23	
R	P	5								0					1								
a			b	c	d				e		f			g	h	i	j	k	l				
optional																							

a	Sensor model
R P 5	Profile

b	Design
G	Magnet slider backlash free (part no. 253 421)
L	Block magnet L (part no. 403 448)
M	U-magnet OD33 (part no. 251 416-2)
N	Magnet slider longer ball-jointed arm (part no. 252 183)
O	No position magnet
S	Magnet slider joint at top (part no. 252 182)
V	Magnet slider joint at front (part no. 252 184)

c	Mechanical options
A	Standard
V	Fluorelastomer seals for the sensor electronics housing

d	Stroke length
X X X X M	0025...6350 mm
Standard stroke length (mm)	Ordering steps
25... 500 mm	25 mm
500...2500 mm	50 mm
2500...5000 mm	100 mm
5000...6350 mm	250 mm

X X X X U	001.0...250.0 in.
Standard stroke length (in.)	Ordering steps
1... 20 in.	1.0 in.
20...100 in.	2.0 in.
100...200 in.	4.0 in.
200...250 in.	10.0 in.

Non-standard stroke lengths are available; must be encoded in 5 mm/0.1 in. increments.

e	Number of magnets
0 X	01...02 Position(s) (1...2 magnet(s))

f	Connection type
D 6 0	M16 male connector (6 pin)
H X X	XX m PUR cable (part no. 530 052) H01...H30 (1...30 m/3...99 ft.) See "Frequently ordered accessories" for cable specifications
R X X	XX m PVC cable (part no. 530 032) R01...R30 (1...30 m/3...99 ft.) See "Frequently ordered accessories" for cable specifications
T X X	XX m Teflon® cable (part no. 530 112) T01...T30 (1...30 m/3...99 ft.) See "Frequently ordered accessories" for cable specifications
*/ Encode in meters if using metric stroke length. Encode in feet if using US customary stroke length	

g	System
1	Standard

h	Output
A	Current
V	Voltage

i	Function
1	Position (1 or 2 magnets/outputs)
2	Position and speed (1 magnet and 2 outputs)
3	Position and velocity (1 magnet and 2 outputs)
4	Position and reverse position (1 magnet and 2 outputs)
5	Position and temperature inside the sensor electronics housing (1 magnet and 2 outputs)
6	Differential (2 magnets and 1 output)

j	Options
0	Standard
3	Over range output mode

k	Output range
0	0...10 VDC or 4...20 mA
1	10...0 VDC or 20...4 mA
2	-10...+10 VDC or 0...20 mA
3	+10...-10 VDC or 20...0 mA
V	0...10 VDC for position, -10...+10 VDC for velocity

<b>I</b>	Max speed or velocity value
<b>(optional: use when <b>i</b> "Function" is 2 or 3)</b>	
<input type="checkbox"/> <input type="checkbox"/> <input type="checkbox"/>	For metric stroke lengths encode speed or velocity in m/s for the values 0.01 to 9.99 m/s (001...999) For US customary stroke lengths encode speed or velocity in inches/s for the values 1 to 400 in./s (001...400)
Use the codes (00E) for 0.025 m/s, and (A00) for 10.0 m/s to provide backwards compatibility for these predecessor models of the R-Series.	

**NOTICE**

- For RP5, the magnet selected in **b** "Design" is included in the scope of delivery. Specify the number of magnets for your application. For multi-position measurements with more than 1 magnet order the other magnets separately.
- The number of magnets is limited by the stroke length. The minimum allowed distance between magnets (i.e. front face of one to the front face of the next one) is 75 mm (3 in.).
- Use magnets of the same type for multi-position measurement, e.g. 2 × U-magnet (part no. 251 416-2).

### 3.2 Order code of Temposonics® RH5

1	2	3	4	5	6	7	8	9	10	11	12	13	14	15	16	17	18	19	20	21	22	23	
R	H	5								0					1								
a			b	c	d				e		f			g	h	i	j	k	l				
optional																							

a	Sensor model
R H 5	Rod

b	Design
B	Base unit (only for replacement)
J	Threaded flange M22×1.5-6g (rod Ø 12.7 mm), stroke length: 25...5900 mm (1...232 in.)
M	Threaded flange M18×1.5-6g (standard)
S	Threaded flange ¾"-16 UNF-3A (standard)
T	Threaded flange ¾"-16 UNF-3A (with raised-face)

c	Mechanical options
A	Standard
B	Bushing on rod end (only for design »M«, »S« & »T«)
M	Thread M4 at rod end (only for design »M«, »S« & »T«)
V	Fluorelastomer seals for the sensor electronics housing

d	Stroke length
X X X X M	0025...7620 mm
Standard stroke length (mm)      Ordering steps	
25... 500 mm	5 mm
500... 750 mm	10 mm
750...1000 mm	25 mm
1000...2500 mm	50 mm
2500...5000 mm	100 mm
5000...7620 mm	250 mm
X X X X U	001.0...300.0 in.
Standard stroke length (in.)      Ordering steps	
1... 20 in.	0.2 in.
20... 30 in.	0.4 in.
30... 40 in.	1.0 in.
40...100 in.	2.0 in.
100...200 in.	4.0 in.
200...300 in.	10.0 in.
Non-standard stroke lengths are available; must be encoded in 5 mm/0.1 in. increments.	

e	Number of magnets
0 X	01...02 Position(s) (1...2 magnet(s))

f	Connection type
D 6 0	M16 male connector (6 pin)
H X X	XX m PUR cable (part no. 530 052) H01...H30 (1...30 m/3...99 ft.) See "Frequently ordered accessories" for cable specifications
R X X	XX m PVC cable (part no. 530 032) R01...R30 (1...30 m/3...99 ft.) See "Frequently ordered accessories" for cable specifications
T X X	XX m Teflon® cable (part no. 530 112) T01...T30 (1...30 m/3...99 ft.) See "Frequently ordered accessories" for cable specifications
*/ Encode in meters if using metric stroke length. Encode in feet if using US customary stroke length	

g	System
1	Standard

h	Output
A	Current
V	Voltage

i	Function
1	Position (1 or 2 magnets/outputs)
2	Position and speed (1 magnet and 2 outputs)
3	Position and velocity (1 magnet and 2 outputs)
4	Position and reverse position (1 magnet and 2 outputs)
5	Position and temperature inside the sensor electronics housing (1 magnet and 2 outputs)
6	Differential (2 magnets and 1 output)

j	Options
0	Standard
3	Over range output mode

k	Output range
0	0...10 VDC or 4...20 mA
1	10...0 VDC or 20...4 mA
2	-10...+10 VDC or 0...20 mA
3	+10...-10 VDC or 20...0 mA
V	0...10 VDC for position, -10...+10 VDC for velocity

I	Max speed or velocity value
<b>(optional: use when I "Function" is 2 or 3)</b>	
<input type="checkbox"/> <input type="checkbox"/> <input type="checkbox"/>	For metric stroke lengths encode speed or velocity in m/s for the values 0.01 to 9.99 m/s (001...999) For US customary stroke lengths encode speed or velocity in inches/s for the values 1 to 400 in./s (001...400)
Use the codes (00E) for 0.025 m/s, and (A00) for 10.0 m/s to provide backwards compatibility for these predecessor models of the R-Series.	

**NOTICE**

- Specify the number of magnets for your application and order the magnets separately.
- The number of magnets is limited by the stroke length. The minimum allowed distance between magnets (i.e. front face of one to the front face of the next one) is 75 mm (3 in.).
- Use magnets of the same type for multi-position measurement, e.g. 2 × U-magnet (part no. 251 416-2).



### 3.3 Nameplate

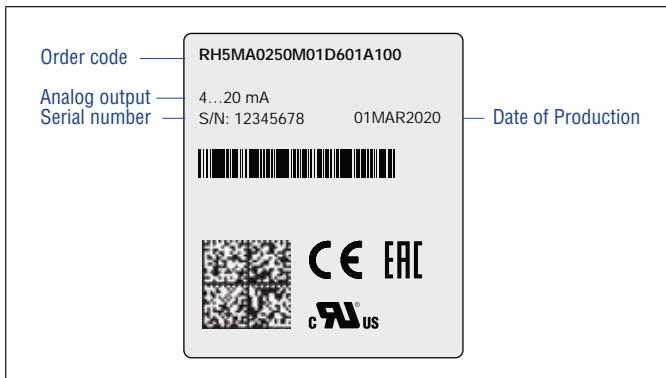

Fig. 1: Example of nameplate of a R-Series V RH5 sensor with Analog output

### 3.4 Approvals

- CE certified
- EAC certified
- UL certified

### 3.5 Scope of delivery

#### RP5 (profile sensor):

- Sensor
- Position magnet (not valid for RP5 with design »0«)
- 2 mounting clamps up to 1250 mm (50 in.) stroke length +  
1 mounting clamp for each 500 mm (20 in.) additional stroke length

#### RH5 (rod sensor):

- RH5-B: Base unit (without flange/rod assembly),  
3 socket screws M4
- RH5-J/M/S/T: Sensor, O-ring

## 4. Product description and commissioning

### 4.1 Functionality and system design

#### Product designation

- Position sensor Temposonics® R-Series V

#### Sensor model

- Temposonics® R-Series V RP5 (profile sensor)
- Temposonics® R-Series V RH5 (rod sensor)

#### Stroke length

- Temposonics® R-Series V RP5: 25...6350 mm (1...250 in.)
- Temposonics® R-Series V RH5: 25...7620 mm (1...300 in.)

#### Output signal

- Analog

#### Application

The Temposonics® position sensors are used for measurement and conversion of the length (position) variable in the fields of automated systems and mechanical engineering.

#### Principle of operation and system construction

The absolute, linear position sensors provided by MTS Sensors rely on the company's proprietary Temposonics® magnetostrictive technology, which can determine position with a high level of precision and robustness. Each Temposonics® position sensor consists of a ferromagnetic waveguide, a position magnet, a strain pulse converter and supporting electronics. The magnet, connected to the object in motion in the application, generates a magnetic field at its location on the waveguide. A short current pulse is applied to the waveguide. This creates a momentary radial magnetic field and torsional strain on the waveguide. The momentary interaction of the magnetic fields releases a torsional strain pulse that propagates the length of the waveguide. When the ultrasonic wave reaches the end of the waveguide it is converted into an electrical signal. Since the speed of the ultrasonic wave in the waveguide is precisely known, the time required to receive the return signal can be converted into a linear position measurement with both high accuracy and repeatability.

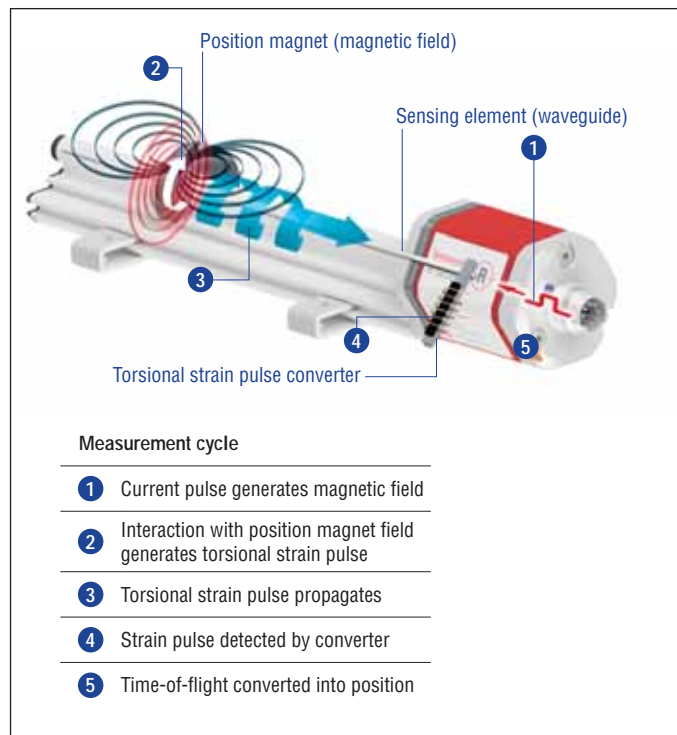

Fig. 2: Time-based magnetostrictive position sensing principle

#### Modular mechanical and electronic construction

- The sensor rod or profile protects the inner sensor element.
- The sensor electronics housing, a rugged aluminum construction, contains the complete electronic interface with active signal conditioning.
- The external position magnet is a permanent magnet. Mounted on the mobile machine part, it travels along the sensor rod or profile and triggers the measurement through the sensor rod wall.
- The sensor can be connected directly to a control system. Its electronics generates a strictly position-proportional signal output between start and end position.

## 4.2 Styles and installation of Temposonics® RP5

### RP5-M-A/-V, example: Connection type D60 (connector output)

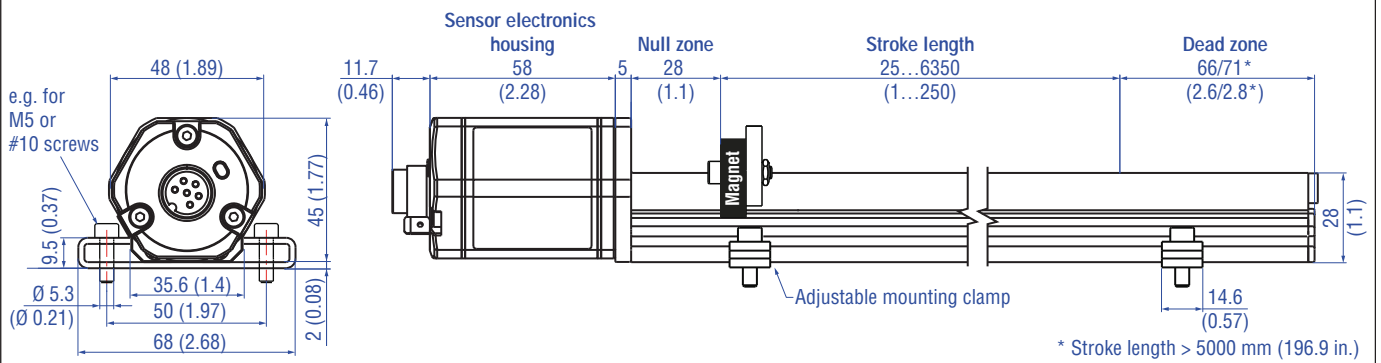

### RP5-M-A/-V, example: Connection type HXX/RXX/TXX (cable output)

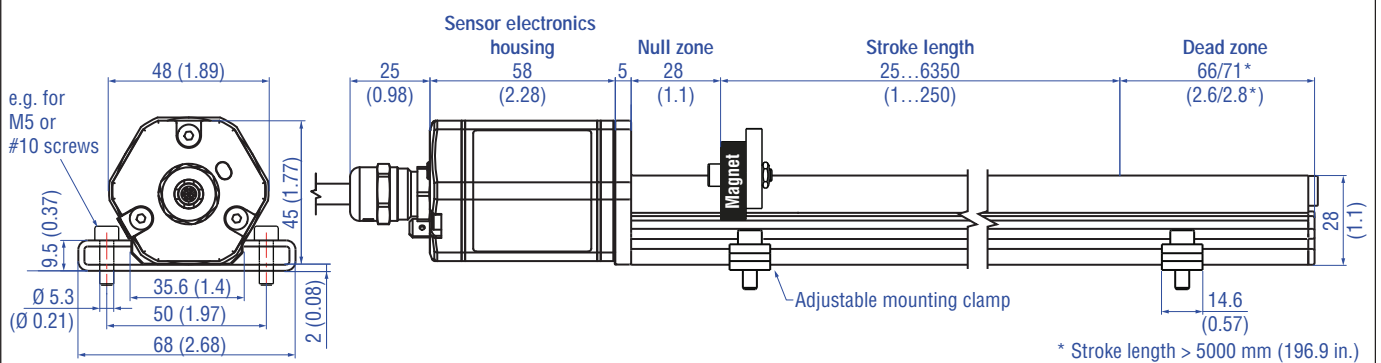

Controlling design dimensions are in millimeters and measurements in ( ) are in inches

Fig. 3: Temposonics® RP5 with U-magnet

### Installation of RP5

The position sensor can be installed in any position. Normally, the sensor is firmly installed and the position magnet is fastened to the mobile machine part. Thus it can travel along the sensor profile. The sensor is fitted on a flat machine surface using the mounting clamps (Fig. 4). A length-dependent number of these clamps are delivered with the sensor and must be distributed over the profile at regular distances. For fastening use M5×20 screws to DIN 6912 that should be tightened with a fastening torque of 5 Nm.

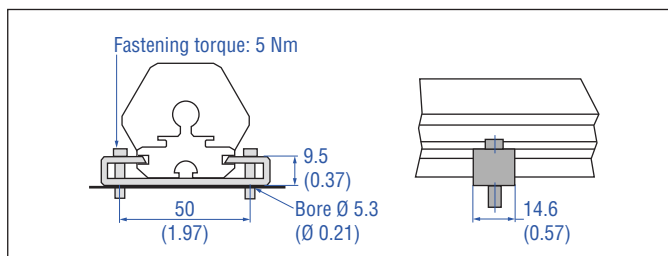

Fig. 4: Mounting clamps (part no. 400 802) with cylinder screw M5×20

### Alternative:

If only limited space is available, the profile sensor can be mounted also via the T-rail in the profile bottom using a T-slot nut M5 (part no. 401 602) or a sliding block (Fig. 5).

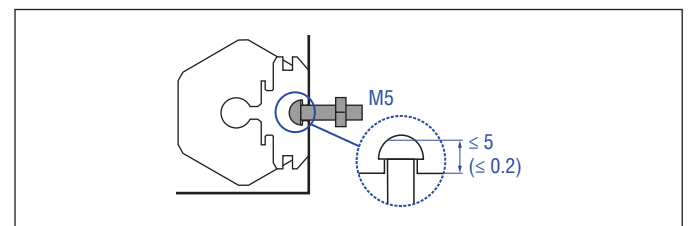

Fig. 5: T-slot nut M5 (part no. 401 602)

### NOTICE

Take care to mount the sensor in an axially parallel position to avoid damage to magnet and sensor.

Controlling design dimensions are in millimeters and measurements in ( ) are in inches

4.3 Styles and installation of Temposonics® RH5

RH5-M/S-A-V – RH5 with threaded flange M18×1.5-6g or ¾"-16 UNF-3A, example: Connection type D60 (connector output)

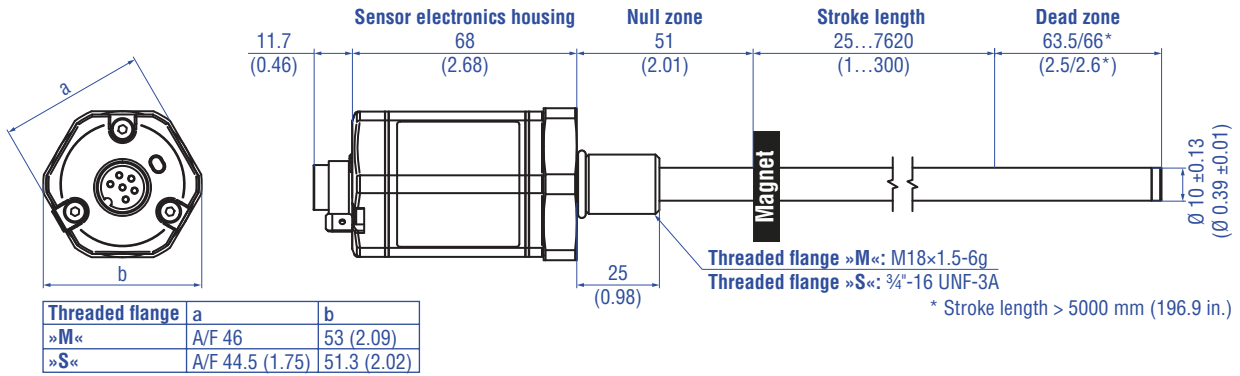

RH5-T-A/-V – RH5 with threaded flange ¾"-16 UNF-3A with raised-face, example: Connection type HXX/RXX/TXX (cable output)

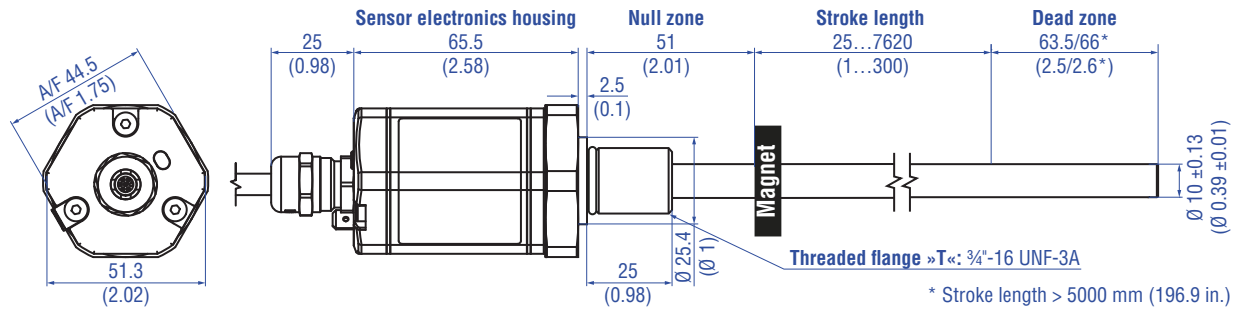

Mechanical option »B«: Bushing on rod end for threaded flange M18×1.5-6g or ¾"-16 UNF-3A

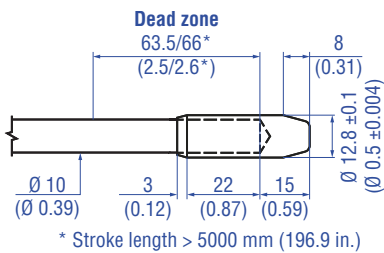

Mechanical option »M«: Thread M4 at rod end for threaded flange M18×1.5-6g or ¾"-16 UNF-3A

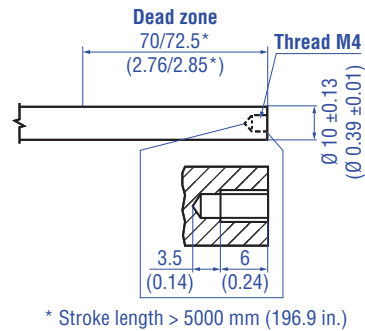

Controlling design dimensions are in millimeters and measurements in ( ) are in inches

Fig. 6: Temposonics® RH5 with ring magnet, part 1

**RH5-J-A/-V – RH5 with threaded flange M22×1.5-6g and Ø 12.7 mm rod, example: Connection type D60 (connector output)**

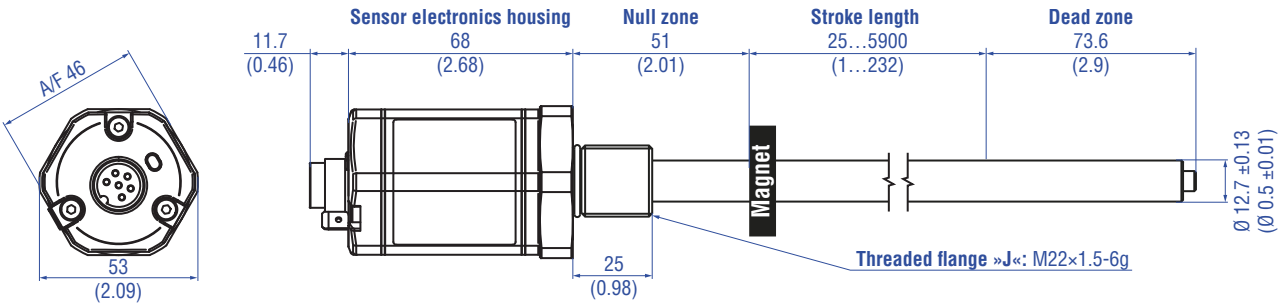

**RH5-B-A/-V – RH5 base unit (only for replacement), example: Connection type D60 (connector output)**

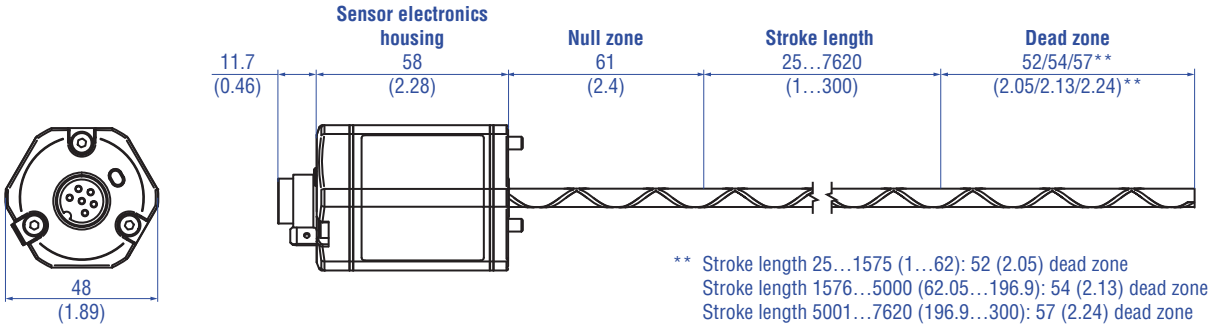

Controlling design dimensions are in millimeters and measurements in ( ) are in inches

Fig. 7: Temposonics® RH5 with ring magnet, part 2

**Installation of RH5 with threaded flange**

Fix the sensor rod via threaded flange M18×1.5-6g, M22×1.5-6g or ¾"-16 UNF-3A.

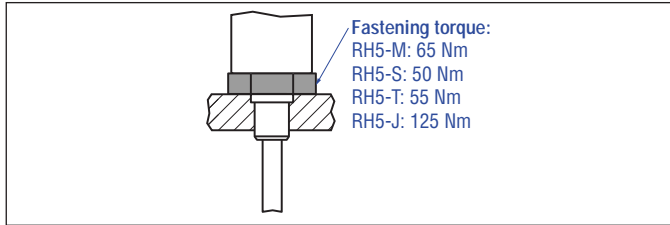

Fig. 8: Mounting example of threaded flange

**Installation of a rod-style sensor in a fluid cylinder**

The rod-style version has been developed for direct stroke measurement in a fluid cylinder. Mount the sensor via threaded flange or a hex nut.

- Mounted on the face of the piston, the position magnet travels over the rod without touching it and indicates the exact position through the rod wall – independent of the hydraulic fluid.
- The pressure resistant sensor rod is installed into a bore in the piston rod.
- The base unit is mounted by means of three screws. It is the only part that needs to be replaced if servicing is required, i.e. the hydraulic circuit remains closed. For more information see chapter "4.5 Replacement of base unit" on page 17.

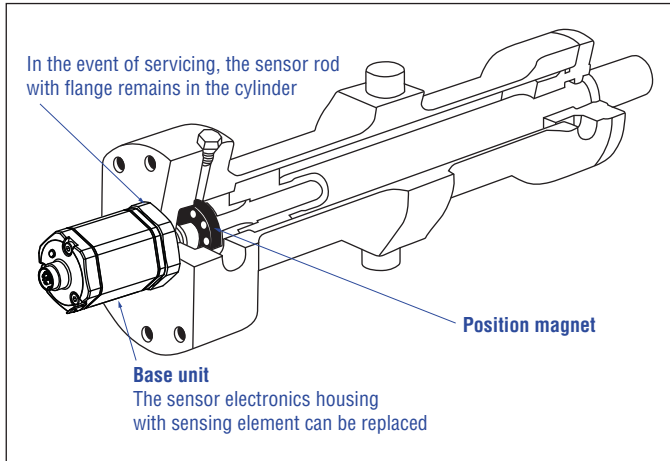

Fig. 9: Sensor in cylinder

**Hydraulics sealing**

There are two ways to seal the flange contact surface (Fig. 10):

1. A sealing by using an O-ring (e.g. 22.4 × 2.65 mm (0.88 × 0.1 in.), 25.07 × 2.62 mm (0.99 × 0.1 in.)) in a cylinder bottom groove.
2. A sealing by using an O-ring in the undercut.

For threaded flange (¾"-16 UNF-3A):

O-ring 16.4 × 2.2 mm (0.65 × 0.09 in.) (part no. 560 315)

For threaded flange (M18×1.5-6g):

O-ring 15.3 × 2.2 mm (0.60 × 0.09 in.) (part no. 401 133)

For threaded flange (M22×1.5-6g):

O-ring 19.2 × 2.2 mm (0.76 × 0.09 in.) (part no. 561 337)

In the case of threaded flange M18×1.5-6g or M22×1.5-6g, provide a screw hole based on ISO 6149-1 (Fig. 11). See ISO 6149-1 for further information.

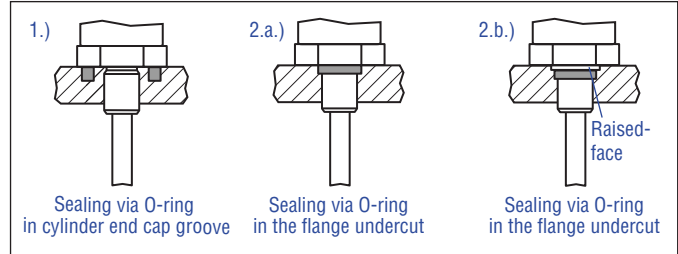

Fig. 10: Possibilities of sealing for threaded flange with flat face 1. + 2.a. (RH5-J/-M/-S) and with raised-face 2.b. (RH5-T)

- Note the fastening torque:  
RH5-M/S: 50 Nm  
RH5-T: 55 Nm  
RH5-J: 125 Nm
- Seat the flange contact surface completely on the cylinder mounting surface.
- The cylinder manufacturer determines the pressure-resistant gasket (copper gasket, O-ring, etc.).
- The position magnet should not grind on the sensor rod.
- The piston rod drilling (RH5-M/S/T-A/M/V with rod Ø 10 mm: ≥ Ø 13 mm (≥ Ø 0.51 in.); RH5-M/S/T-B with rod Ø 10 mm: ≥ Ø 16 mm (≥ Ø 0.63 in.); RH5-J-A/V with rod Ø 12.7 mm: ≥ Ø 16 mm (≥ Ø 0.63 in.)) depends on the pressure and piston speed.
- Adhere to the information relating to operating pressure.
- Protect the sensor rod against wear.

Notice for metric threaded flanges									
Thread (d <sub>1</sub> ×P)	d <sub>2</sub>	d <sub>3</sub>	d <sub>4</sub>	d <sub>5</sub> +0.1 0	L <sub>1</sub> +0.4 0	L <sub>2</sub>	L <sub>3</sub>	L <sub>4</sub>	Z° ±1°
<b>RH5-M-A/M/V</b>									
M18×1.5-6g	55	≥ 13	24.5	19.8	2.4	28.5	2	26	15°
<b>RH5-M-B</b>									
M18×1.5-6g	55	≥ 16	24.5	19.8	2.4	28.5	2	26	15°
<b>RH5-J-A/V</b>									
M22×1.5-6g	55	≥ 16	27.5	23.8	2.4	28.5	2	26	15°

Fig. 11: Notice for metric threaded flange M18×1.5-6g / M22×1.5-6g based on DIN ISO 6149-1

#### 4.4 Magnet installation

##### Typical use of magnets



Magnet	Typical sensors	Benefits
 Ring magnets	Rod model (RH5)	<ul style="list-style-type: none"> <li>Rotationally symmetrical magnetic field</li> </ul>
 U-magnets	Profile & rod models (RP5, RH5)	<ul style="list-style-type: none"> <li>Height tolerances can be compensated, because the magnet can be lifted off</li> </ul>
 Block magnets	Profile & rod models (RP5, RH5)	<ul style="list-style-type: none"> <li>Height tolerances can be compensated, because the magnet can be lifted off</li> </ul>
 Magnet sliders	Profile models (RP5)	<ul style="list-style-type: none"> <li>The magnet is guided by the profile</li> <li>The distance between the magnet and the waveguide is strictly defined</li> <li>Easy coupling via the ball joint</li> </ul>

Fig. 12: Typical use of magnets

##### Mounting ring magnets, U-magnets & block magnets

Install the magnet using non-magnetic material for mounting device, screws, spacers etc.. The magnet must not grind on the sensor rod. Alignment errors are compensated via the air gap.

- Permissible surface pressure: Max. 40 N/mm<sup>2</sup> (only for ring magnets and U-magnets)
- Fastening torque for M4 screws: 1 Nm; use washers, if necessary
- Minimum distance between position magnet and any magnetic material has to be 15 mm (0.6 in.) (Fig. 15).
- If no other option exists and magnetic material is used, observe the specified dimensions (Fig. 15).

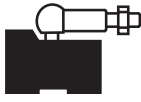
##### NOTICE

Mount ring magnets and U-magnets concentrically. Mount block magnets centrally over the sensor rod or the sensor profile. The maximum permissible air gap must not be exceeded (Fig. 13 / Fig. 14). Take care to mount the primary sensor axis in parallel to the magnet path in order to avoid damage to the carriage, magnet and sensor rod.

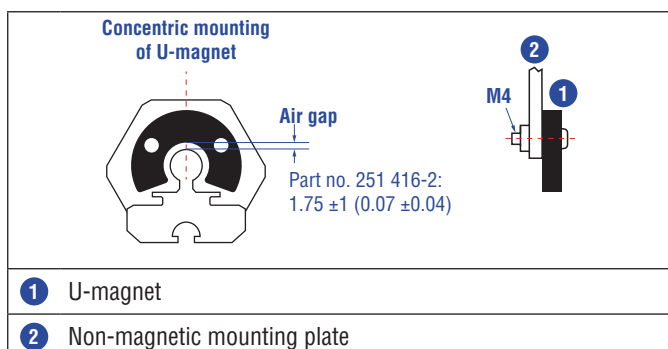

Fig. 13: Mounting of U-magnet (part no. 251 416-2 or part no. 201 553)

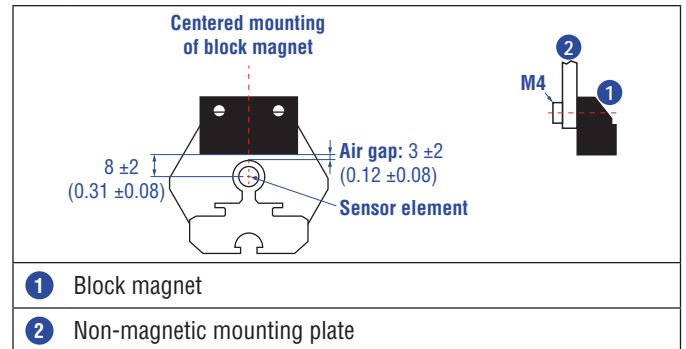

Fig. 14: Mounting of block magnet (part no. 403 448)

##### Magnet mounting with magnetic material

When using magnetic material the dimensions of Fig. 15 must be observed.

- A.** If the position magnet aligns with the drilled piston rod
- B.** If the position magnet is set further into the drilled piston rod, install another non-magnetic spacer (e.g. part no. 400 633) above the magnet.

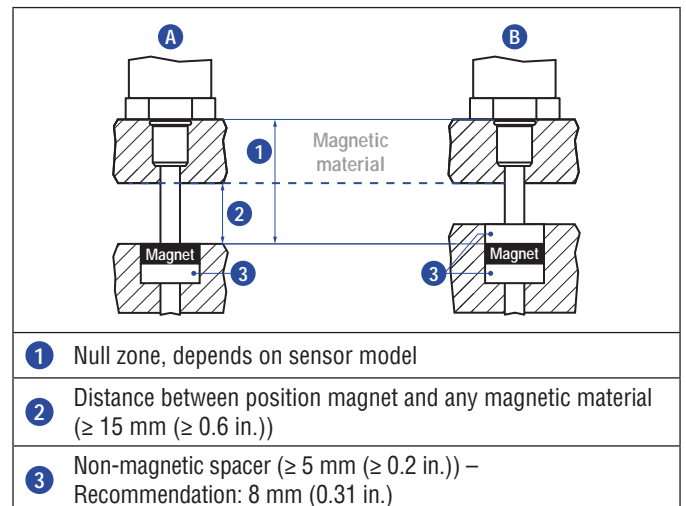

Fig. 15: Installation with magnetic material

##### Sensors with stroke lengths ≥ 1 meter (3.3 ft.)

Support horizontally installed sensors with a stroke length from 1 meter (3.3 ft.) mechanically at the rod end. Without the use of a support, rod and position magnet may be damaged. A false measurement result is also possible. Longer rods require evenly distributed mechanical support over the entire length (e.g. part no. 561 481). Use an U-magnet (Fig. 16) for measurement.

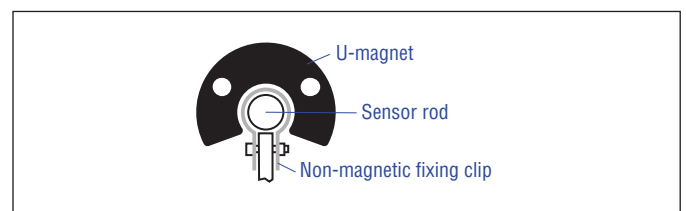

Fig. 16: Example of sensor support (part no. 561 481)

Controlling design dimensions are in millimeters and measurements in ( ) are in inches

**Start- and end positions of the position magnets**

Consider the start and end positions of the position magnets during the installation. To ensure that the entire stroke length is electrically usable, the position magnet must be mechanically mounted as follows.

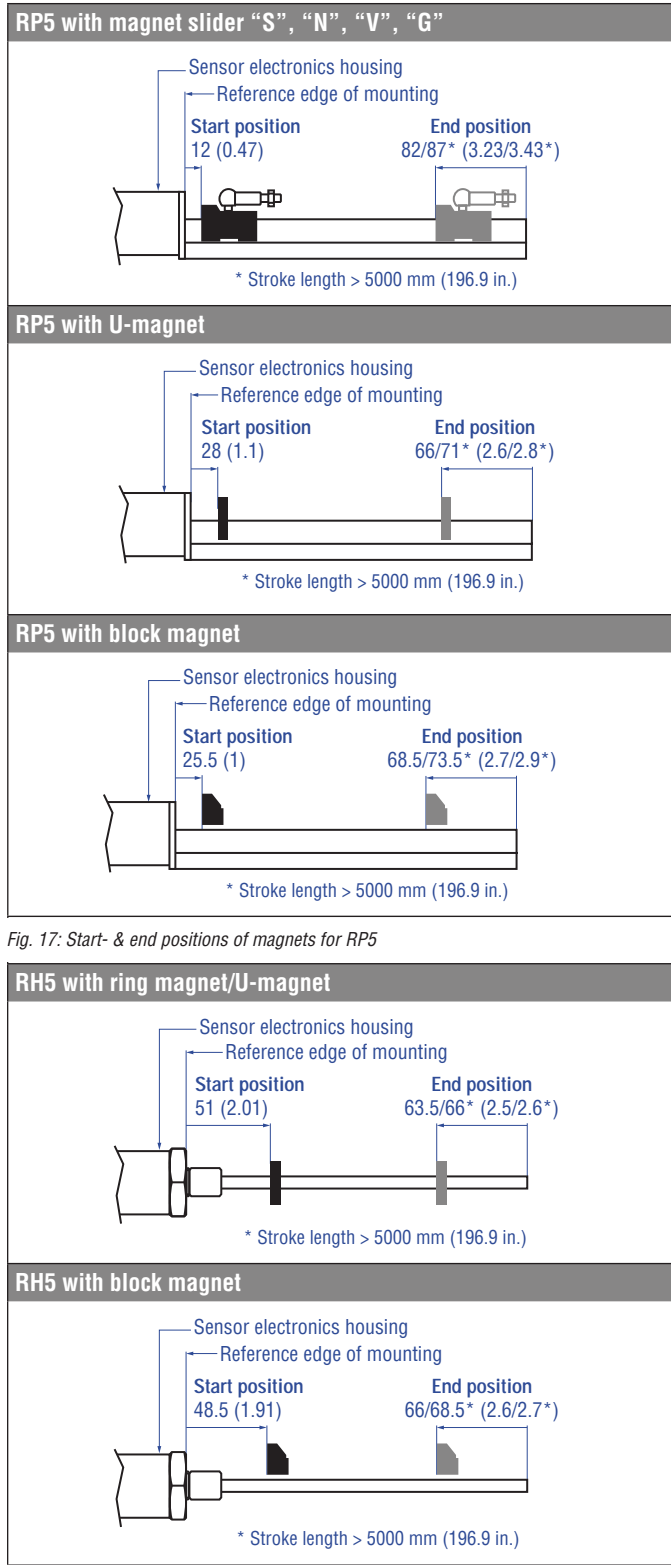

Fig. 18: Start- & end positions of magnets for RH5

**NOTICE**

On all sensors, the areas left and right of the active stroke length are provided for null and dead zone. These zones should not be used for measurement, however the active stroke length can be exceeded.

**Multi-position measurement**

The minimum distance between the magnets is 75 mm (3 in.).

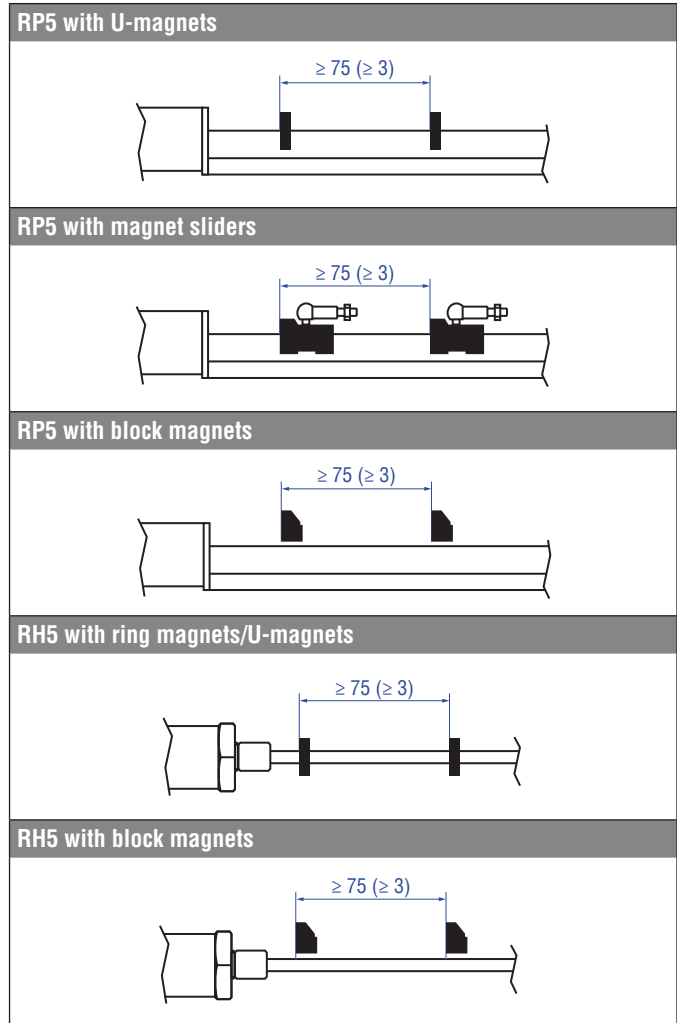

Fig. 19: Minimum distance for multi-position measurement

**NOTICE**

For multi-position measurement, use magnets of the same type e.g. 2 × U-magnet (part no. 251 416-2). Do not fall below the minimum distance between the magnets of 75 mm (3 in.) for multi-position measurement. Contact MTS Sensors if you need a magnet distance < 75 mm (3 in.).



#### 4.5 Replacement of base unit

The base unit of the sensor model RH5 (RH5-B) is replaceable as shown in Fig. 20 and Fig. 21 for the sensor designs »M«, »S« and »T«. The sensor can be replaced without interrupting the hydraulic circuit.

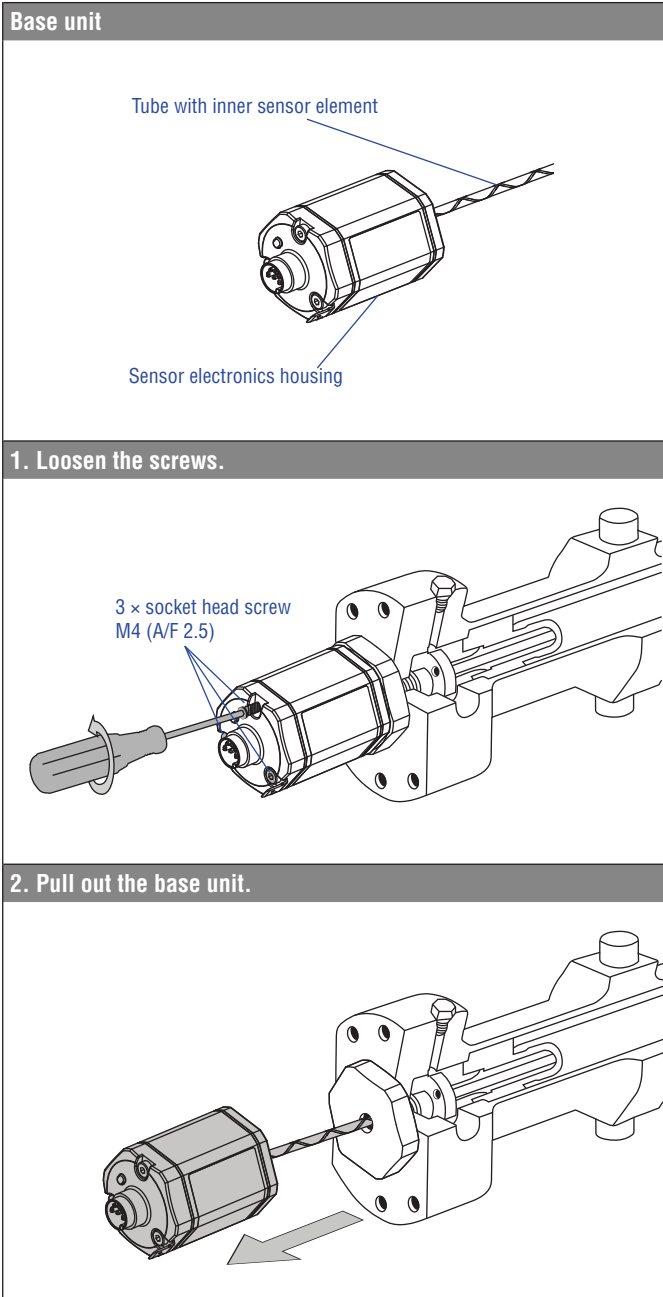

Fig. 20: Replacement of the base unit (e.g. RH5 sensor), part 1

**3. Insert the new base unit.  
Install the ground lug on a screw.  
Tighten the screws.**

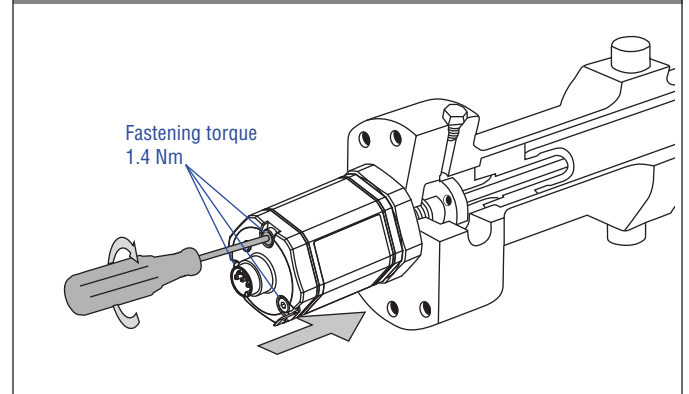

Fig. 21: Replacement of the base unit (e.g. RH5 sensor), part 2

#### NOTICE

- If the R-Series V replaces a predecessor model of the R-Series, the plastic tube in the sensor rod must be removed.
- When replacing the base unit, make sure that no humidity enters the sensor tube. This may damage the sensor.
- Secure the base unit screws, e.g. using Loctite 243, before re-installing.

#### 4.6 Electrical connections

Placement of installation and cabling have decisive influence on the sensor's electromagnetic compatibility (EMC). Hence correct installation of this active electronic system and the EMC of the entire system must be ensured by using suitable metal connectors, shielded cables and grounding. Overvoltages or faulty connections can damage its electronics despite protection against wrong polarity.

#### NOTICE

1. Do not mount the sensors in the area of strong magnetic or electric noise fields.
2. Never connect / disconnect the sensor when voltage is applied.

#### Instructions for connection

- Use low-resistant twisted pair and shielded cables. Connect the shield to ground externally via the controller equipment.
  - Keep control and signal cables separate from power cables and sufficiently far away from motor cables, frequency inverters, valve lines, relays, etc..
  - Use only connectors with metal housing and connect the shielding to the connector housing.
  - Keep the connection surface at both shielding ends as large as possible. Connect the cable clamps to function as a ground.
  - Keep all non-shielded leads as short as possible.
  - Keep the earth connection as short as possible with a large cross section. Avoid ground loops.
  - With potential differences between machine and electronics earth connections, no compensating currents are allowed to flow across the cable shielding.
- Recommendation:  
Install potential compensating leads with large cross section, or use cables with separate double shielding, and connect only one end of the shield.
- Use only stabilized power supplies in compliance with the specified connecting ratings.

#### Grounding of profile and rod sensors

Connect the sensor electronics housing to machine ground. Ground sensor types RP5 and RH5 via ground lug as shown in Fig. 22. In addition you can ground the sensor type RH5 via thread.

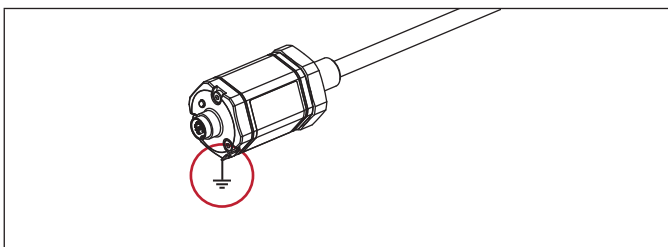

Fig. 22: Grounding via ground lug (e.g. RH5)

#### Connector wiring

Connect the sensor directly to the control system, indicator or other evaluating systems as shown.

#### NOTICE

1. In addition to the functions listed for the output 2 wiring connections, pins 3 and 4 (or the yellow and green wires) can also be used with the hand or cabinet programmers for analog output to perform field programming of the setpoint 1 and 2 positions (refer to section 5.4).
2. If output 2 is not used, these connections should still remain available for possible field programming with the hand or cabinet programmers for analog output. However, to avoid accidentally engaging the programming mode on sensor power up, these connections must be insulated to prevent shorting with each other or being grounded.

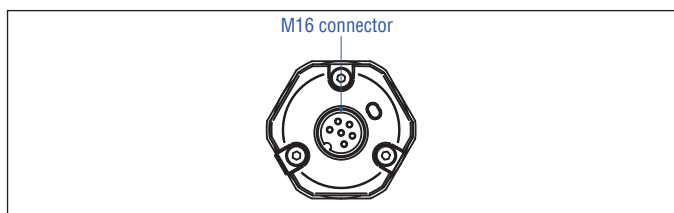

Fig. 23: Location of connection

D60			
Signal + power supply			
M16 male connector	Output	Pin	Function
<p>View on sensor</p>	1	1	Position (magnet 1)
		2	Signal Ground
	2*	3	Position (magnet 2) or reverse position (magnet 1) or speed or velocity (magnet 1) or temperature inside the sensor electronics housing
		4	Signal Ground
		5	+12...30 VDC (±20 %)
		6	DC Ground (0 V)

\* order dependent

Fig. 24: Connector wiring D60

HXX / RXX / TXX			
Signal + power supply			
Cable	Output	Color	Function
	1	GY	Position (magnet 1)
		PK	Signal Ground
	2*	YE	Position (magnet 2) or reverse position (magnet 1) or speed or velocity (magnet 1) or temperature inside the sensor electronics housing
		GN	Signal Ground
		BN	+12...30 VDC (±20 %)
		WH	DC Ground (0 V)

\* order dependent

For cable type TXX, the extra red & blue wires are not used.

Fig. 25: Wiring for cable outlet

4.7 Frequently ordered accessories for RP5 design – Additional options available in our [Accessories Guide](#) 551 444

Position magnets

<p><b>Magnet slider S, joint at top</b> <b>Part no. 252 182</b></p> <p>Material: GRP, magnet hard ferrite Weight: Approx. 35 g Operating temperature: -40...+85 °C (-40...+185 °F)</p>	<p><b>Magnet slider V, joint at front</b> <b>Part no. 252 184</b></p> <p>Material: GRP, magnet hard ferrite Weight: Approx. 35 g Operating temperature: -40...+85 °C (-40...+185 °F)</p>	<p><b>Magnet slider N</b> <b>longer ball-joint arm</b> <b>Part no. 252 183</b></p> <p>Material: GRP, magnet hard ferrite Weight: Approx. 35 g Operating temperature: -40...+85 °C (-40...+185 °F)</p>	<p><b>Magnet slider G, backlash free</b> <b>Part no. 253 421</b></p> <p>Material: GRP, magnet hard ferrite Weight: Approx. 25 g Operating temperature: -40...+85 °C (-40...+185 °F)</p>

Position magnets

Mounting accessories

<p><b>U-magnet OD33</b> <b>Part no. 251 416-2</b></p> <p>Material: PA ferrite GF20 Weight: Approx. 11 g Surface pressure: Max. 40 N/mm<sup>2</sup> Fastening torque for M4 screws: 1 Nm Operating temperature: -40...+105 °C (-40...+221 °F)</p>	<p><b>Block magnet L</b> <b>Part no. 403 448</b></p> <p>Material: Plastic carrier with hard ferrite magnet Weight: Approx. 20 g Fastening torque for M4 screws: 1 Nm Operating temperature: -40...+75 °C (-40...+167 °F)</p> <p>This magnet may influence the sensor performance specifications for some applications.</p>	<p><b>Mounting clamp</b> <b>Part no. 400 802</b></p> <p>Material: Stainless steel (AISI 304)</p>	<p><b>T-nut</b> <b>Part no. 401 602</b></p> <p>Fastening torque for M5 screw: 4.5 Nm</p>

**4.8 Frequently ordered accessories for RH5 design** – Additional options available in our [Accessories Guide](#) 551 444

**Position magnets**

<p><b>U-magnet OD33</b> Part no. 251 416-2</p> <p>Material: PA ferrite GF20 Weight: Approx. 11 g Surface pressure: Max. 40 N/mm<sup>2</sup> Fastening torque for M4 screws: 1 Nm Operating temperature: -40...+105 °C (-40...+221 °F)</p>	<p><b>Ring magnet OD33</b> Part no. 201 542-2</p> <p>Material: PA ferrite GF20 Weight: Approx. 14 g Surface pressure: Max. 40 N/mm<sup>2</sup> Fastening torque for M4 screws: 1 Nm Operating temperature: -40...+105 °C (-40...+221 °F)</p>	<p><b>Ring magnet OD25.4</b> Part no. 400 533</p> <p>Material: PA ferrite Weight: Approx. 10 g Surface pressure: Max. 40 N/mm<sup>2</sup> Operating temperature: -40...+105 °C (-40...+221 °F)</p>	<p><b>Ring magnet</b> Part no. 402 316</p> <p>Material: PA ferrite coated Weight: Approx. 13 g Surface pressure: Max. 20 N/mm<sup>2</sup> Operating temperature: -40...+100 °C (-40...+212 °F)</p>

**Position magnet**

**Magnet spacer**

**O-rings**







<p><b>Block magnet L</b> Part no. 403 448</p> <p>Material: Plastic carrier with hard ferrite magnet Weight: Approx. 20 g Fastening torque for M4 screws: 1 Nm Operating temperature: -40...+75 °C (-40...+167 °F)</p> <p>This magnet may influence the sensor performance specifications for some applications.</p>	<p><b>Magnet spacer</b> Part no. 400 633</p> <p>Material: Aluminum Weight: Approx. 5 g Surface pressure: Max. 20 N/mm<sup>2</sup> Fastening torque for M4 screws: 1 Nm</p>	<p><b>O-ring for threaded flange</b> <b>M18×1.5-6g</b> Part no. 401 133</p> <p>Material: Fluoroelastomer Durometer: 75 ± 5 Shore A Operating temperature: -40...+204 °C (-40...+400 °F)</p>	<p><b>O-ring for threaded flange</b> <b>¾"-16 UNF-3A</b> Part no. 560 315</p> <p>Material: Fluoroelastomer Durometer: 75 ± 5 Shore A Operating temperature: -40...+204 °C (-40...+400 °F)</p>

**O-ring**

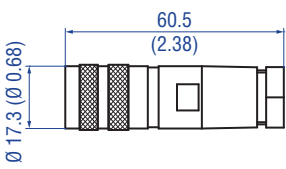
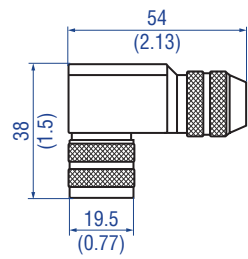
**Mounting accessories**

<p><b>O-ring for threaded flange</b> <b>M22×1.5-6g</b> Part no. 561 337</p> <p>Material: FPM Durometer: 75 Shore A Operating temperature: -20...+200 °C (-6...+392 °F)</p>	<p><b>Hex jam nut M18×1.5-6g</b> Part no. 500 018</p> <p>Material: Steel, zinc plated</p>	<p><b>Hex jam nut ¾"-16 UNF-3A</b> Part no. 500 015</p> <p>Material: Steel, zinc plated</p>	<p><b>Fixing clip</b> Part no. 561 481</p> <p>Application: Used to secure sensor rods (Ø 10 mm (Ø 0.39 in.)) when using an U-magnet or block magnet Material: Brass, non-magnetic</p>

**4.9 Frequently ordered accessories for Analog output** – Additional options available in our [Accessories Guide](#) 551 444

Cable connectors*		Programming tools	
			
<p><b>M16 female connector (6 pin), straight</b> <b>Part no. 370 423</b></p> <p>Material: Zinc nickel plated Termination: Solder Cable Ø: 6...8 mm (0.24...0.31 in.) Operating temperature: –40...+100 °C (–40...+212 °F) Ingress protection: IP65/IP67 (correctly fitted) Fastening torque: 0.6 Nm</p>	<p><b>M16 female connector (6 pin), angled</b> <b>Part no. 370 460</b></p> <p>Material: Zinc nickel plated Termination: Solder Cable Ø: 6...8 mm (0.24...0.31 in.) Wire: 0.75 mm<sup>2</sup> (20 AWG) Operating temperature: –40...+95 °C (–40...+203 °F) Ingress protection: IP67 (correctly fitted) Fastening torque: 0.6 Nm</p>	<p><b>TempoLink kit for Temposonics® R-Series V</b> <b>Part no. TL-1-0-AD60 (for D60)</b> <b>Part no. TL-1-0-AS00 (for cable output)</b></p> <ul style="list-style-type: none"> <li>• Connect wirelessly via Wi-Fi enabled device or via USB with the diagnostic tool</li> <li>• Simple connectivity to the sensor via 24 VDC power line (permissible cable length: 30 m)</li> <li>• User friendly interface for mobile devices and desktop computers</li> <li>• See data sheet “TempoLink smart assistant” (document part no.: <a href="#">552070</a>) for further information</li> </ul>	<p><b>Hand programmer for analog output</b> <b>Part no. 253 124</b></p> <p>Easy teach-in-setups of stroke length and direction on desired zero / span positions. For sensors with 1 magnet.</p>
Programming tool		Cables	
			
<p><b>Cabinet programmer for analog output</b> <b>Part no. 253 408</b></p> <p>Features snap-in mounting on standard DIN rail (35 mm). This programmer can be permanently mounted in a control cabinet and includes a program/run switch. For sensors with 1 magnet.</p>	<p><b>PVC cable</b> <b>Part no. 530 032</b></p> <p>Material: PVC jacket; gray Features: Twisted pair, shielded, flexible Cable Ø: 6 mm (0.23 in.) Cross section: 3 × 2 × 0.14 mm<sup>2</sup> Bending radius: 10 × D (fixed installation) Operating temperature: –40...+105 °C (–40...+221 °F)</p>	<p><b>PUR cable</b> <b>Part no. 530 052</b></p> <p>Material: PUR jacket; orange Features: Twisted pair, shielded, highly flexible, halogen free, suitable for drag chains, mostly oil &amp; flame resistant Cable Ø: 6.4 mm (0.25 in.) Cross section: 3 × 2 × 0.25 mm<sup>2</sup> Bending radius: 5 × D (fixed installation) Operating temperature: –30...+80 °C (–22...+176 °F)</p>	<p><b>Teflon® cable</b> <b>Part no. 530 112</b></p> <p>Material: Teflon® jacket; black Features: Twisted pair, shielded, flexible, high thermal resistance, mostly oil &amp; acid resistant Cable Ø: 7.6 mm (0.3 in.) Cross section: 4 × 2 × 0.25 mm<sup>2</sup> Bending radius: 8 – 10 × D (fixed installation) Operating temperature: –100...+180 °C (–148...+356 °F)</p>

\*/ Follow the manufacturer's mounting instructions

Controlling design dimensions are in millimeters and measurements in ( ) are in inches

Extension cables



**PVC cable with M16 female connector (6 pin), straight – pigtail**

PVC cable (part no. 530 032) with M16 female connector, straight (part no. 370 423)

Order code:  
**MTS-A-370423-xxxx-530032-0**  
(where xxxx is the cable length in centimeters (e.g. code: 0150))



**PUR cable with M16 female connector (6 pin), straight – pigtail**

PUR cable (part no. 530 052) with M16 female connector, straight (part no. 370 423)

Order code:  
**MTS-A-370423-xxxx-530052-0**  
(where xxxx is the cable length in centimeters (e.g. code: 0150))



**Teflon® cable with M16 female connector (6 pin), straight – pigtail**

Teflon® cable (part no. 530 112) with M16 female connector, straight (part no. 370 423)

Order code:  
**MTS-A-370423-xxxx-530112-0**  
(where xxxx is the cable length in centimeters (e.g. code: 0150))

Standard cable lengths

Meters	Feet	Code
1.5	5	0150
2	6.6	0200
4.6	15	0460
5	16.4	0500
7.6	25	0760
10	32.8	1000
15.2	50	1520

For additional extension cables reference the accessory catalog (551444), [page 41](#) for industrial sensors.

## 5. Programming

### 5.1 Analog Output Options

R-Series V analog sensors can be ordered for single channel or dual channel outputs.

The single channel output model provides the position value for a single magnet that is output over a voltage or current range. Also, the single channel output can provide a differential value between 2 magnet positions.

The dual channel output model can provide a magnet position value on one channel and the speed value (without direction) or velocity value (with direction) on the second channel.

Additionally, the dual channel output can be used for applications requiring 2 magnet position values (requires 75 mm minimum distance between magnets), or for one magnet position value along with its reverse-acting value, or for one magnet position and the temperature inside of the electronics housing.

For all these cases, the single channel and dual channel outputs are selectable for their range of values.

#### NOTICE

Note that for the dual channel outputs, channel 1 and 2 have the same output range settings when ordered, but can be later changed using the TempoLink smart assistant.

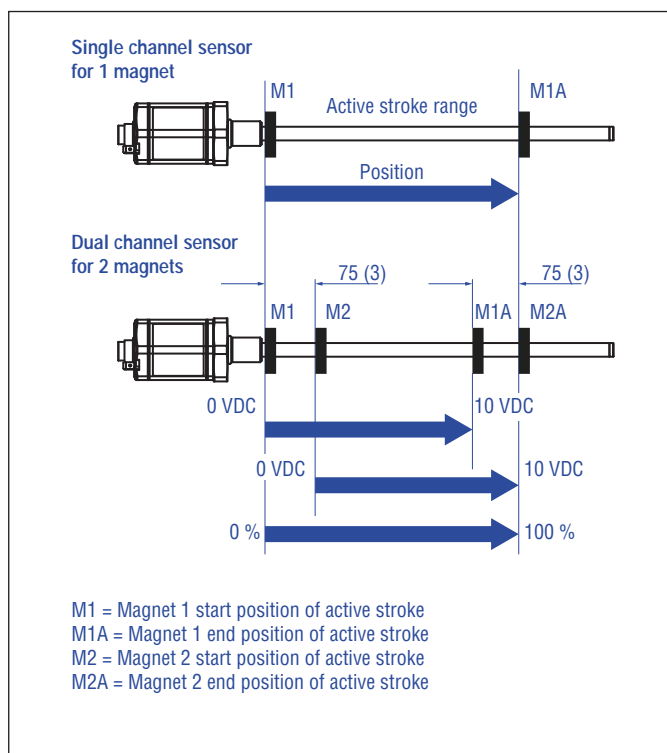

Fig. 26: Active stroke range for 2 magnets, compared to 1 magnet.

### 5.2 Introduction

Temposonics® R-Series V Analog sensors are pre-configured at the factory by the model number ordering code. For many applications, normal sensor installation and operation does not require additional adjustment. If sensor parameter changes are required in the field, there are 3 different service tools that can be used to easily program the sensor electronically. These are: the hand programmer for analog output (part no. 253 124), the cabinet programmer for analog output (part no. 253 408), and the TempoLink smart assistant.

The hand programmer for analog output and the cabinet programmer for analog output can be used to program the magnet positions for the start of output (0 % = 0 VDC, -10 VDC, 4 mA, or 0 mA), and the end of output (100 % = 10 VDC, or 20 mA), for the single magnet version sensor.

Standard factory settings place setpoint 1 (start of stroke) and setpoint 2 (end of stroke) at the limits of the sensor's active stroke range. Both setpoint 1 and 2 can be re-positioned for the actual measuring range needed anywhere within the active stroke length, but a minimum distance of 25 mm is required between the setpoints.

Please note that the hand programmer for analog output and the cabinet programmer for analog output can only be used to program output values for 0 % or 100 %. To adjust the values to other than 0 % or 100 % of the output range, you must use the TempoLink smart assistant.

The TempoLink smart assistant can be used to retrieve the sensor's status and operational data for diagnostics. Additionally, it provides field programming for all of the sensor's settings.



### 5.3 LED Status

The LED on the sensor displays the current sensor status. In normal function the LED is continuously green. In other cases the color of the LED changes in the time slot of 0.5 seconds as shown in Fig. 27.

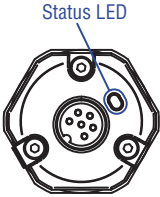
R-Series V Analog LED status				
				
Time slot 1	Time slot 2	Time slot 3	Time slot 4	Information
GN	BU	RD	Off	Configuration error
BU	GN	RD	Off	Storage error
BU	RD	GN	Off	Internal error
RD	Off	RD	Off	Power supply error
GN	Off	GN	Off	Magnet outside set points
GN	RD	BU	Off	Extra magnet
RD + GN	RD + GN	RD + GN	RD + GN	Magnet status error
RD	BU	GN	Off	Signal error
BU	Off	BU	Off	Command mode
GN	GN	GN	GN	Normal function

1 × time slot = 0.5 seconds

Fig. 27: LED status

Fig. 28 describes error conditions that are output via the LEDs and troubleshooting.

Error Condition	Description	Troubleshooting
Configuration Error	Invalid configuration of the sensor	Check the configuration of the sensor. Contact MTS Sensors.
Storage Error	Error in internal data storage	Contact MTS Sensors
Internal Error	Internal error of the sensor	Contact MTS Sensors
Power Supply Error	Power supply of the sensor is out of the allowable range	Set the power supply for the sensor to the allowable range
Magnet outside set points	Position magnet is not in the range between set point 1 and set point 2	Ensure that the position magnet remains within the defined set point range, or program new set point positions
Extra Magnet	Sensor registers more position magnets than set	Ensure that the number of position magnets on the sensor matches the set number
Magnet Status Error	Sensor registers less position magnets than set	Ensure that the number of position magnets on the sensor matches the set number
Signal Error	Internal signal error	Contact MTS Sensors
Position Error	Error in position measurement	Contact MTS Sensors

Fig. 28: Error conditions and troubleshooting

#### NOTICE

##### Observe during commissioning

1. Before initial switch-on, check carefully if the sensor has been connected correctly.
2. Position the magnet in the measuring range of the sensor during first commissioning and after replacement of the magnet.
3. Ensure that the sensor control system cannot react in an uncontrolled way when switching on.
4. Ensure that the sensor is ready and in operation mode after switching on. The LED lights permanently green.
5. Check the preset span start and end values of the measuring range (see chapter 4.4) and correct them via the TempoLink smart assistant, if necessary.



### 5.4 Programming via MTS Sensors service tools

Temposonics® sensors can be easily adapted – without opening the sensor housing – to adjust the measurement operation and parameter settings. Several service tools are available to easily program the sensor electronically using the sensor's connector or cable. These service tools are available as separate accessories.

#### 5.4.1 Programming via hand programmer for analog output

Hand programmer for analog output (part no. 253 124), directly connected to the sensor is provided for setup of measuring range by moving the magnet on desired Null/Span positions (minimum distance between setpoints: 25 mm) and pushing the corresponding 0 % respectively 100 % buttons on programmer.

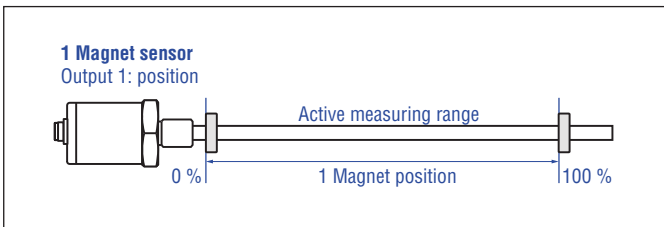

Fig. 29: Standard factory setting

1. Connect the programmer (Fig. 29) and turn on the supply voltage.
2. Activate the programming mode:
  - a.) Press the Start button and 100% button simultaneously. Release the Start button first, wait until the sensor's LED changes from green to flashing blue, then release the 100% button.
  - b.) The flashing blue LED indicates that the sensor is now in command mode.
3. Adjust the position for the start of output, (0 % = 0 VDC, -10 VDC, 4 mA, or 0 mA).
  - a.) Move the magnet to the start position.
  - b.) Press and hold the 0% button until the flashing blue LED changes to flashing green, and then release the 0% button. The LED will then return to flashing blue.
4. Adjust the position for the end of output (100 % = 10 VDC or 20 mA).
  - a.) Move the magnet to the end position.
  - b.) Press and hold the 100% button until the flashing blue LED changes to flashing green, and then release the 100 % button. The LED will then return to flashing blue.
5. Save your settings and exit the command mode:
  - a.) Press and release the Start button. The LED will change from flashing blue to green on.
  - b.) Turn off the supply voltage and disconnect the programmer.

### NOTICE

In normal function the green LED on sensor is glowing permanently.

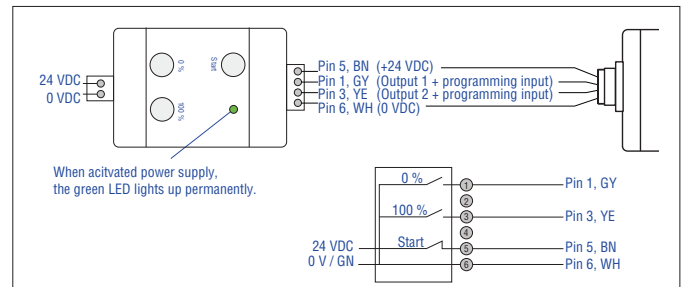

Fig. 30: Connecting the programmer

### 5.4.2 Programming via cabinet programmer for analog output

Cabinet programmer for analog output (part no. 253 408), connected between sensor and control unit is provided for setup of measuring range by moving the magnet on desired Null/Span positions (minimum distance between setpoints: 25 mm) and pushing the corresponding 0 % respectively 100 % buttons on programmer.

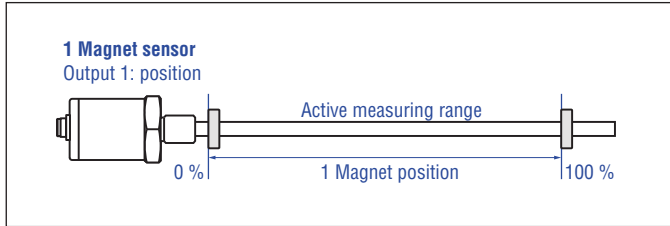

Fig. 31: Connecting the programmer

#### Mounting

The programmer electronics housing is designed for snap-in mounting on standard 35 mm rails (EN 607 15/50022). It is suitable for connection between sensor and controller in a cabinet. The programming mode can be activated without any additional service tool at any time.

#### Normal function:

1. Slide the Program/Run switch to run (all sensor leads are connected to the controller).
  - a.) The sensor LED is green to indicate normal function.

#### Activate the programming mode:

1. Slide the Program/Run switch to program.
  - a.) Press the Start button and 100% button simultaneously. Release the Start button first, wait until the sensor's LED changes from green to flashing blue, then release the 100% button.
  - b.) The flashing blue LED indicates that the sensor is now in command mode.
2. Adjust the position for the start of output, (0 % = 0 VDC, -10 VDC, 4 mA, or 0 mA).
  - a.) Move the magnet to the start position.
  - b.) Press and hold the 0 % button until the flashing blue LED changes to flashing green, and then release the 0% button. The LED will then return to flashing blue.
3. Adjust the position for the end of output (100 % = 10 VDC or 20 mA).
  - a.) Move the magnet to the end position.
  - b.) Press and hold the 100% button until the flashing blue LED changes to flashing green, and then release the 100 % button. The LED will then return to flashing blue.
4. Save your settings and exit the command mode:
  - a.) Press and release the Start button. The LED will change from flashing blue to green on.
  - b.) Slide the Program/Run switch to run.

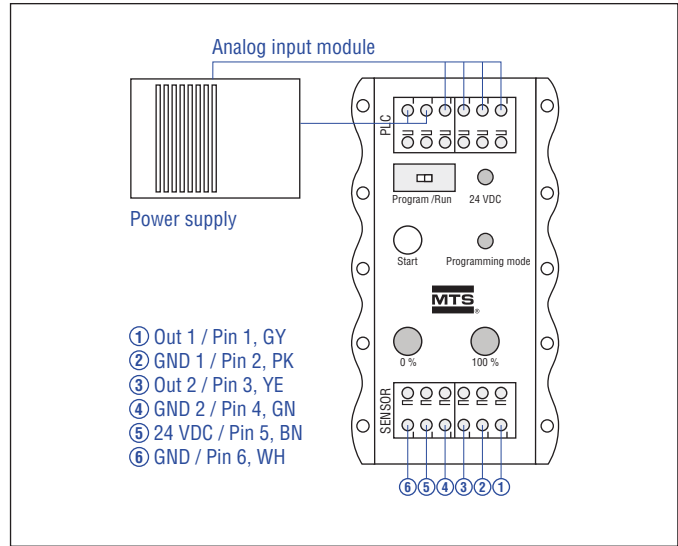

Fig. 32: Connecting sensor with cabinet programmer

## 5.5 Programming and configuration

### 5.5.1 Connection of TempoLink smart assistant to sensor and power supply

The TempoLink smart assistant can be connected to all sensors of the R-Series V family. Use the adapter cable for connection of the TempoLink smart assistant to the R-Series V sensor. Connect the barrel connector of the adapter cable to the connection point labeled “OUTPUT SENSOR” on the TempoLink smart assistant. Next, connect the female connector of the adapter cable to the connector at the R-Series V Analog sensor. If the sensor is connected to a control disconnect it before connecting TempoLink smart assistant to the sensor.

Next, connect the female connector of the adapter cable to the connector at the R-Series V Analog sensor. For sensors with the cable connection types, use the adapter cable with terminal clamps on the ends to grasp each of the matching color cable wires from the sensor.

#### NOTICE

When disconnecting the power supply of the sensor possibly error messages occur at the connected controller.

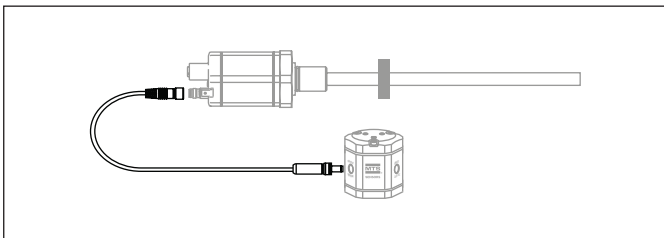

Fig. 33: Connection of TempoLink smart assistant to R-Series V sensor

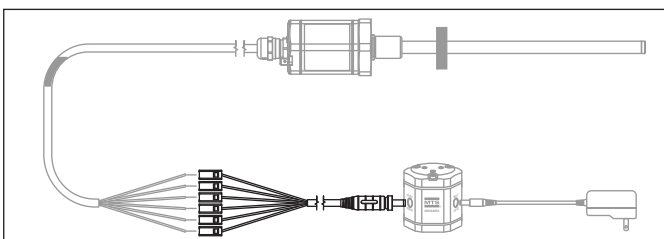

Fig. 34: Connection of TempoLink smart assistant to R-Series V sensor with cable output

The TempoLink smart assistant can be used to configure the sensor's settings and to retrieve the sensor's status and operational data for diagnostics.

The TempoLink smart assistant is connected to the sensor as a stand-alone device. In this case TempoLink is powered via the supplied plug-in power supply. Connect the barrel connector to the “INPUT 24 VDC” port on the TempoLink smart assistant. Next, insert the plug into the outlet. Additional outlet adapters are supplied to support regional requirements.

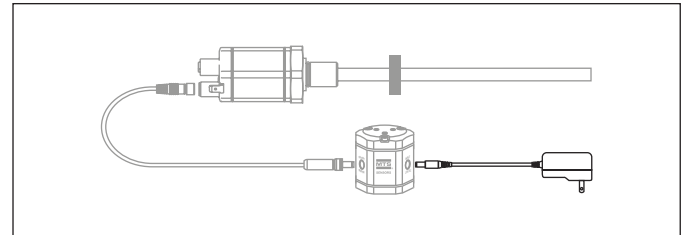

Fig. 35: Connection of TempoLink smart assistant as a stand-alone device

### 5.5.2 Connection of TempoLink smart assistant to smartphone, tablet or computer

Connect to a smartphone, tablet or computer to display the graphical user interface of the TempoLink smart assistant.

#### Connecting a Wi-Fi enabled device to the integrated Wi-Fi access point<sup>3</sup>

Activate Wi-Fi on the device and choose the network “TempoLink\_ xxxx” (xxxx indicates the last four digits of the serial number). The default password is the serial number printed on the label on the bottom of the TempoLink smart assistant.



Fig. 36: Choose the network “TempoLink\_ xxxx” in the Wi-Fi settings of the Wi-Fi-enabled device

#### NOTICE

If you are using a mobile device, ensure cellular data is off. Depending on your operation system, message can appear, that there is no internet access. TempoLink smart assistant does not need internet access.

Connecting to the user interface may take longer if Wi-Fi and LAN connections are active.

3/ The integrated Wi-Fi access point does not provide internet access

**Connecting a computer via USB connection**

The TempoLink smart assistant can also be connected via USB. If the computer is Wi-Fi enabled deactivate Wi-Fi on the computer before setting up the USB connection.

Connect the USB cable with the micro USB connector to the port labeled “USB” on the TempoLink smart assistant. Next, connect the USB type-A connector to a free USB port of the computer. The USB connection simulates a network card. In the folder “network connections” on the computer the connection is shown as “IP-over-USB” or “Remote NDIS”.

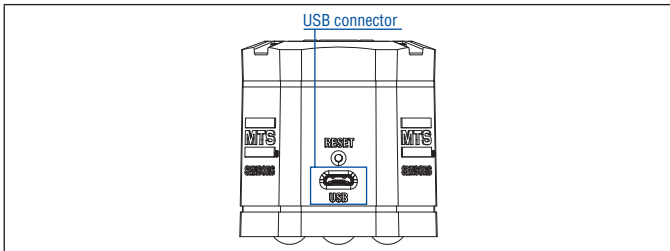

Fig. 37: USB port on the TempoLink smart assistant

**NOTICE**

Only one device can be connected to the TempoLink smart assistant at a time in order to display the graphical user interface.

**NOTICE**

Disable all Wi-Fi and LAN connections before connecting TempoLink smart assistant via USB.  
 Connecting to the user interface may take longer if Wi-Fi and LAN connections are active.

**5.5.3 Establishing a connection via browser**

After the connection via Wi-Fi or USB is established, open the browser and go to the website-URL: tempolink.local/

The connection icon in the top right shows the status of the connection between the TempoLink smart assistant and the sensor.



Fig. 38: Start page of the graphical user interface

Connection status		
<b>Green</b>	<b>Information</b>	
● ON		Connection to sensor is established
<b>Red</b>	<b>Information</b>	
● ON		Connection to sensor is not established
<b>Blue</b>	<b>Information</b>	
● ON		Sensor in command mode

Fig. 39: Connection status

**5.5.4 Adjusting Sensor Settings Using the TempoLink Smart Assistant**

1. The menu item interface shows the R-Series V Analog sensor settings and provides for the adjustment of their values.

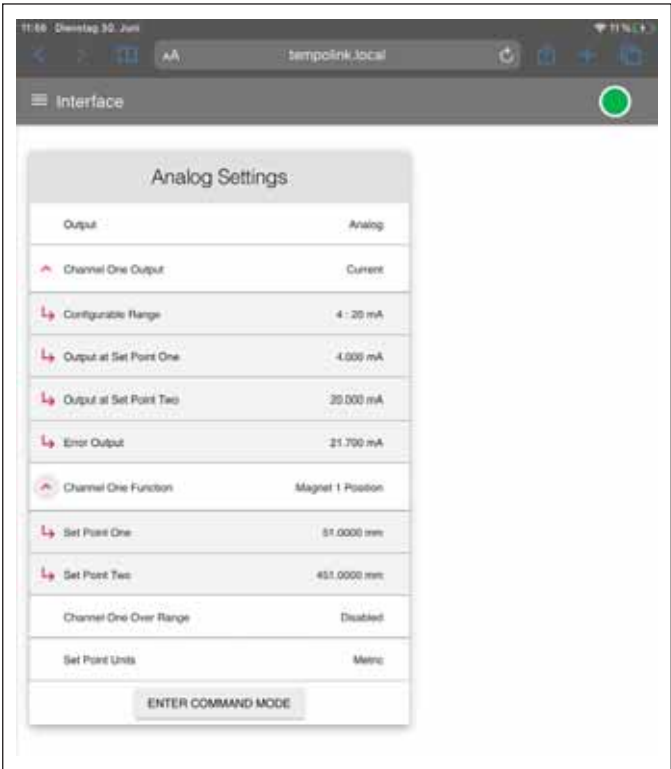

Fig. 40: Interface page for R-Series V Analog sensors

2. To adjust the sensor settings click “Enter Command Mode” on the Interface page, type “COMMAND” into the text field, and then click “OK”.

**NOTICE**  
If the sensor is in command mode, the sensor may cease to output valid magnet position values.

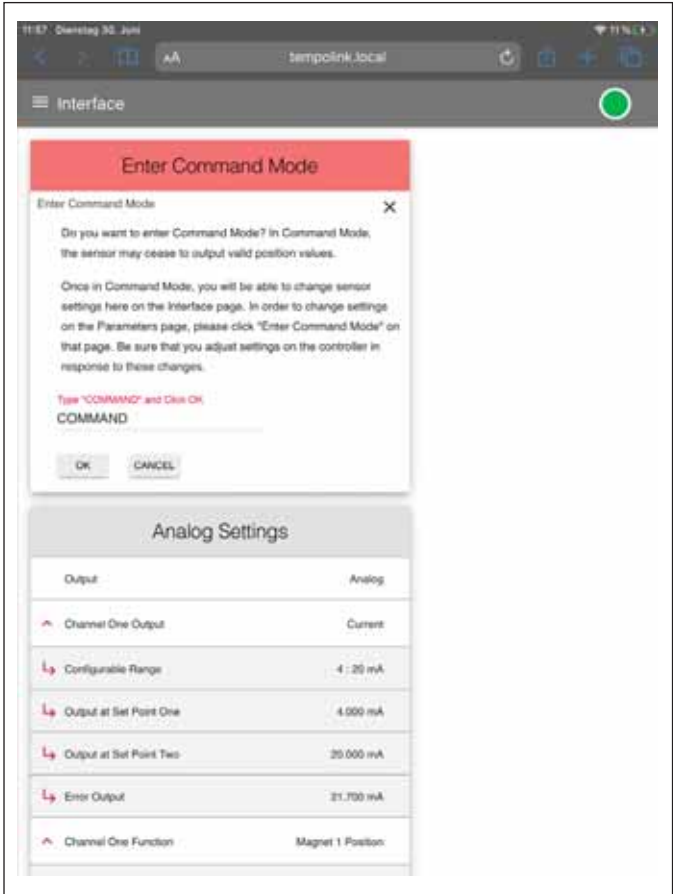

Fig. 41: Entering analog command mode

3. After entry into command mode, the connection icon in the top right will change from green to blue, and the sensor settings can now be adjusted by clicking on the pencil icons next to the list of values.

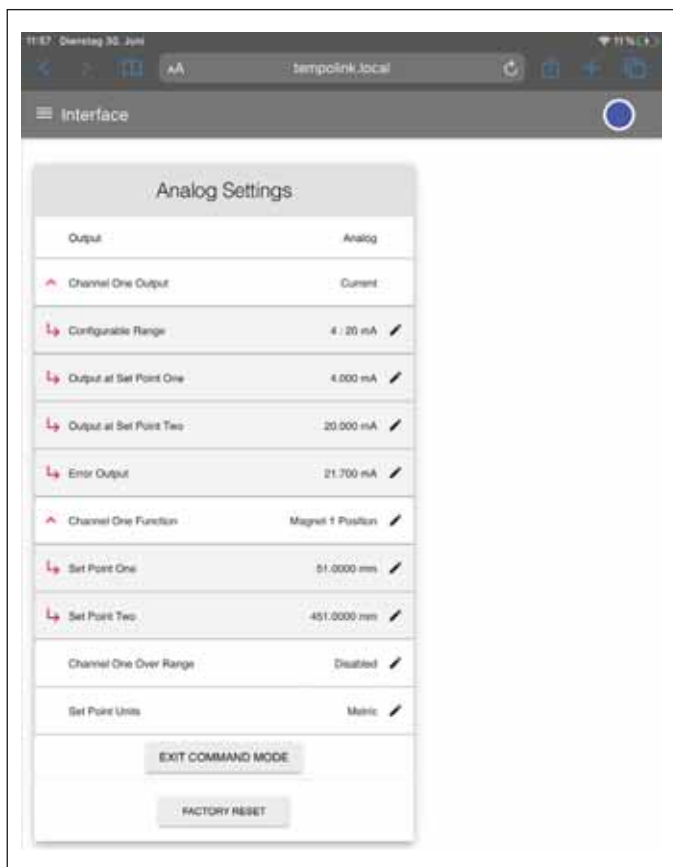

Fig. 42: Sensor settings can be adjusted in analog command mode

4. The sensor shown in this example has been configured in the factory for an output range of 4...20 mA. By clicking the pencil to the right of "Configurable Range" the pencil changes to red and a drop-down box is opened to allow adjusting the values. For this example, the output range is changed to 0...20 mA. You can change the values via the drop-down menu. Confirm your changes by clicking the SUBMIT button.

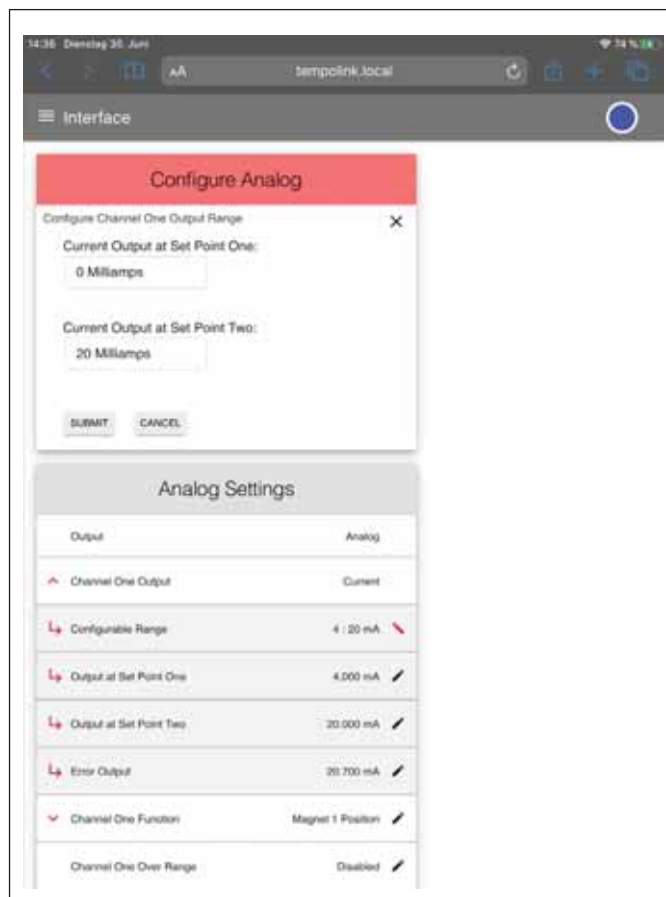

Fig. 43: Adjusting the sensor's output range

5. The next setting is for output at set point one (start of stroke).  
 For this example, the new value is 0.1 mA, as shown in the drop-down box. Confirm your changes by clicking the SUBMIT button.

6. The next setting is for output at set point two (end of stroke).  
 The new value entered in the drop-down box is 19.9 mA. Confirm your changes by clicking the SUBMIT button.

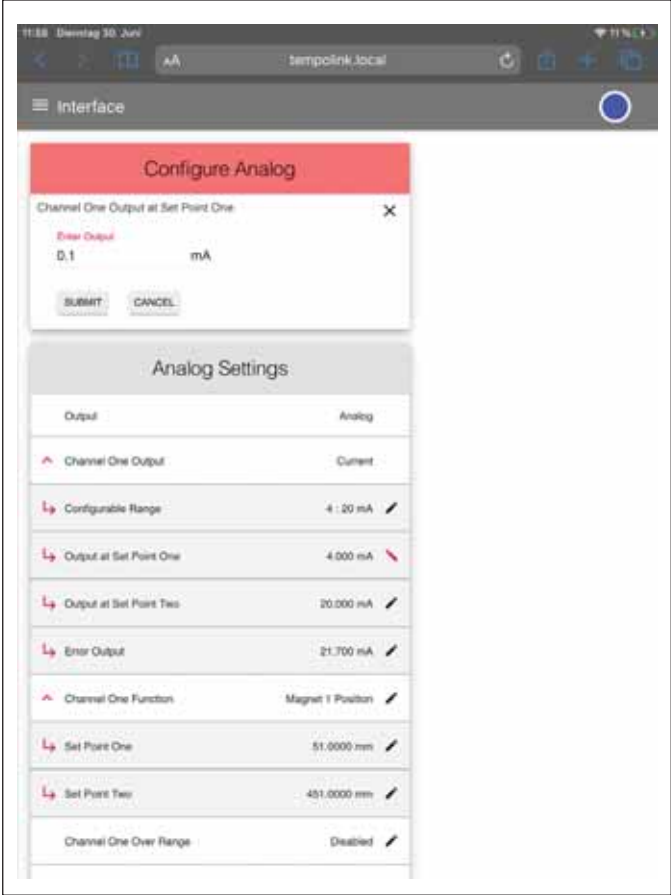

Fig. 44: Adjusting the output value for set point one

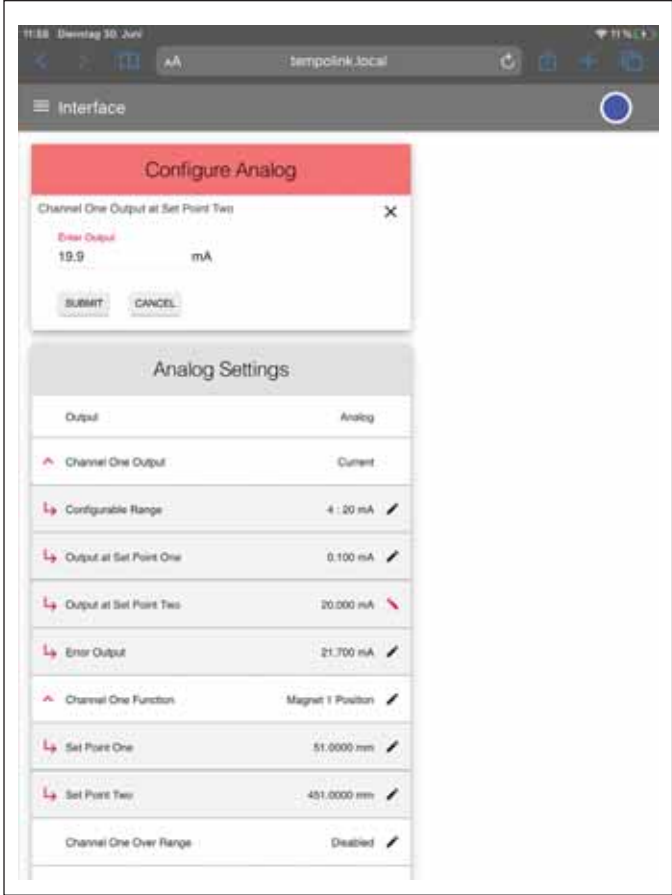

Fig. 45: Adjusting the output value for set point two

7. The last setting for channel one output is for the error output value. For this example, the factory default value of 20.7 mA is changed to 20.5 mA. Confirm your changes by clicking the SUBMIT button.

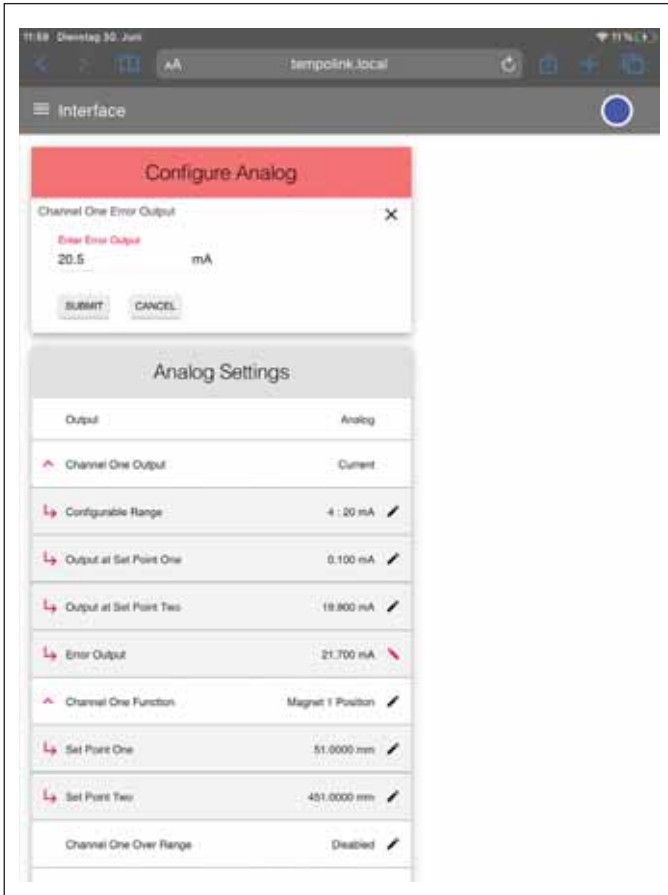

Fig. 46: Adjusting the error output value

8. The factory setting for channel one function is magnet 1 position. For most all applications this setting is not typically changed. For sensors ordered with 2 output channels, the Channel Two Function setting can be used for the other available output functions. These are: magnet 2 position, magnet 1 speed, magnet 1 velocity, magnet 1 reverse position, temperature inside the sensor electronics housing, and the differential between magnet 1 and 2.

For this example with 1 output channel, the next setting can be used to adjust the magnet 1 positions for set point one (start of stroke) and set point two (end of stroke). Click on “Read Magnet” to retrieve the currently measured position value for magnet 1. Confirm your changes by clicking the SUBMIT button.

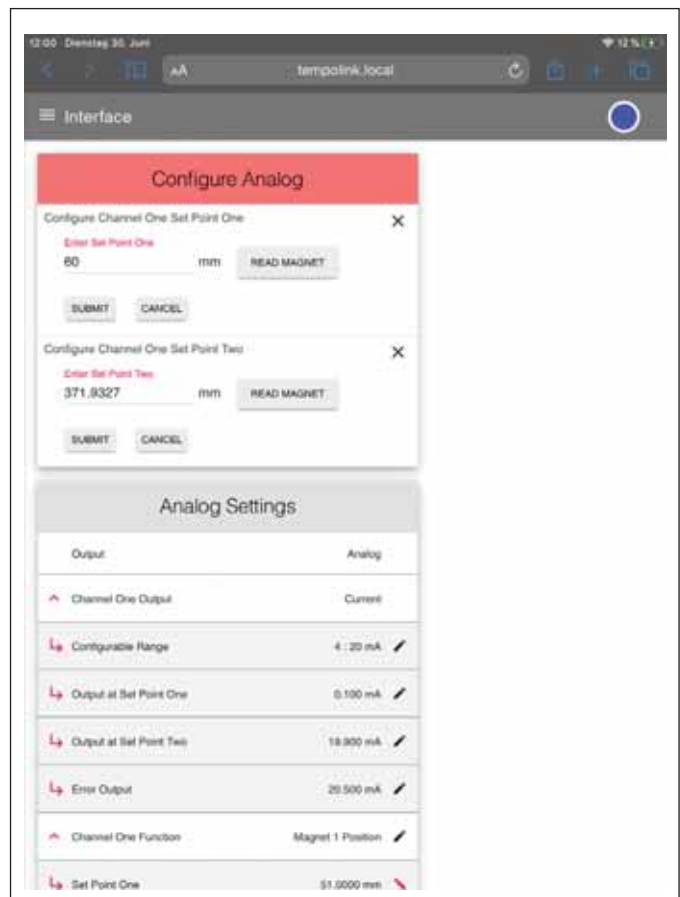

Fig. 47: Adjusting magnet 1 set point positions



9. The channel one over range setting allows the position output values to continue to increase or decrease when the magnet travels beyond the active stroke range. In some instances, controllers that were programmed to expect the position values to continue changing, even when the magnet travels into the null or dead zone areas, can trigger a controller error condition when using the R-Series V Analog sensor, unless this over range setting is enabled. Confirm your changes by clicking the SUBMIT button.

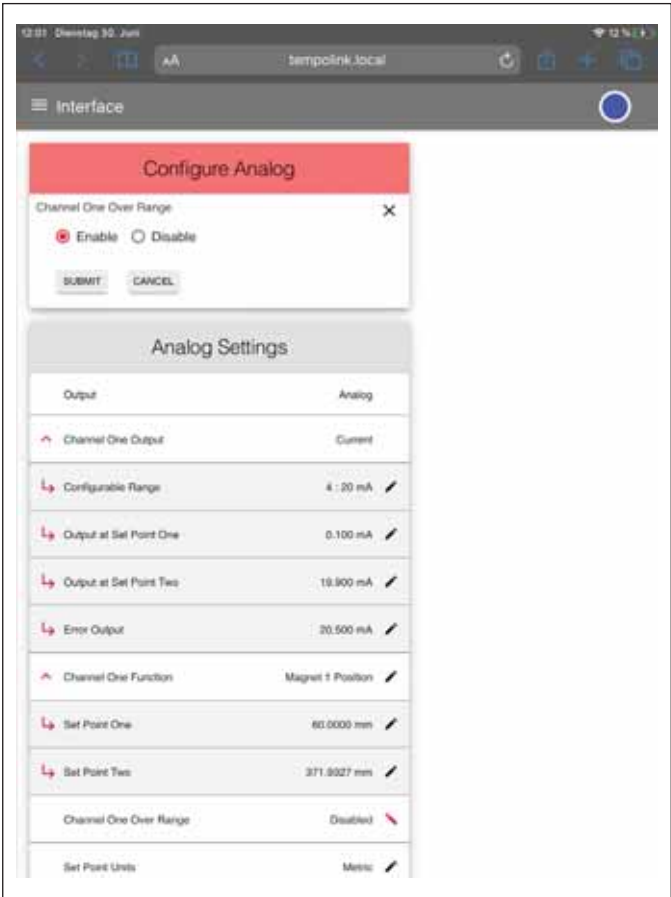

Fig. 48: Enabling the channel one over range setting

10. The set point units setting can be used to change between millimeters and inches. Confirm your changes by clicking the SUBMIT button.

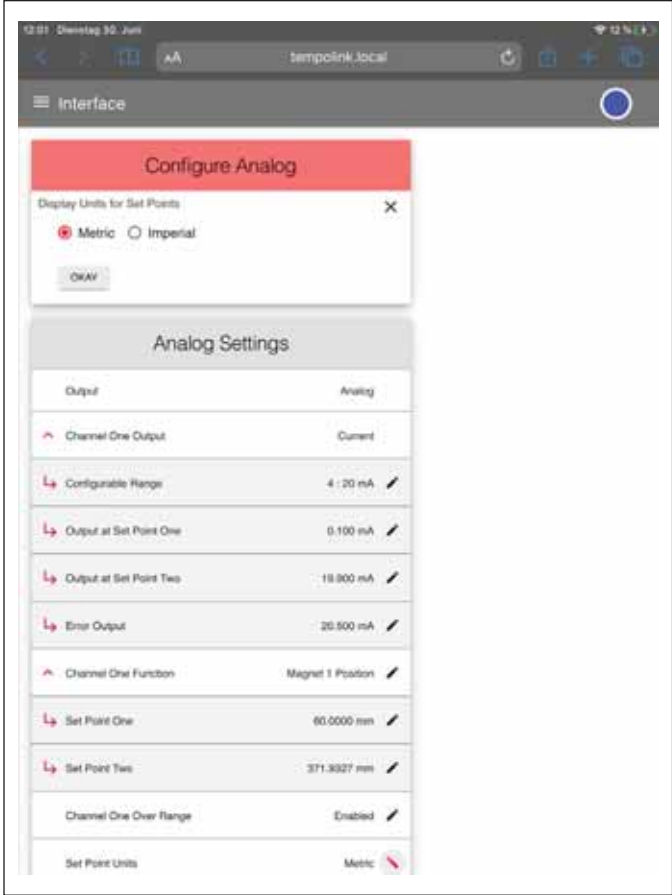

Fig. 49: Adjusting the set point units between millimeters and inches

11. After the parameters have been configured, click the button EXIT COMMAND MODE. The “Exit Command Mode” window for exiting the command mode will open. Click the button SAVE AND EXIT to exit the command mode and to transfer the changed parameters to the sensor (Fig. 50). If you click the button CANCEL, the changed parameters are not transferred to the sensor. The sensor returns to the normal function and outputs the current position value. The connection icon on the top right will turn to green.

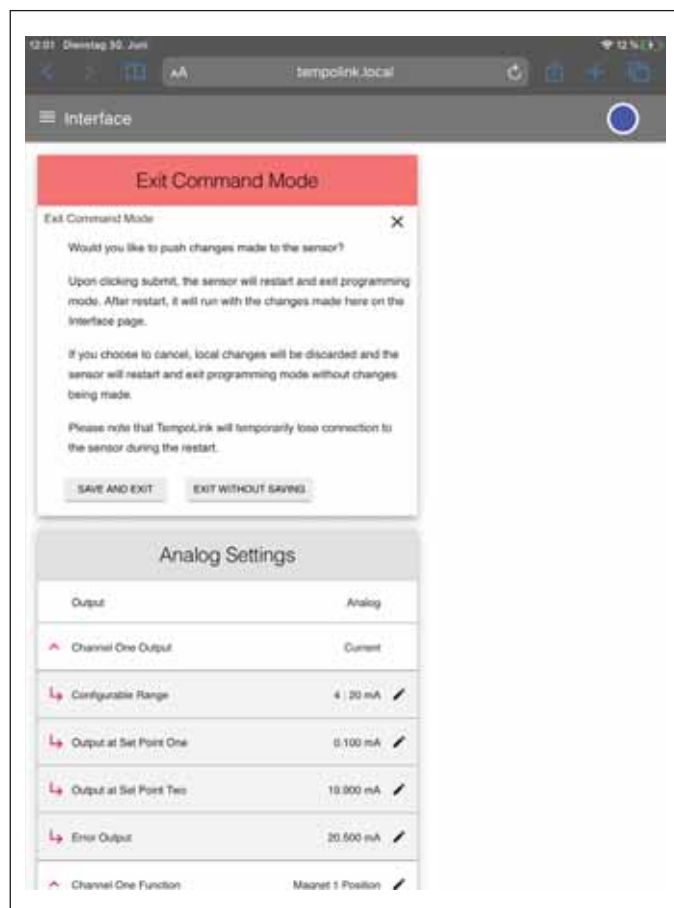

Fig. 50: Exiting the command mode

12. If the original factory settings need to be restored to the sensor, click on “FACTORY RESET” while in the command mode. Like the command mode entry process, resetting the sensor requires typing “RESET” into a drop down text box and clicking the appropriate button.

#### NOTICE

For detailed information about the TempoLink smart assistant see its operation manual (document no. 551 986).

## 6. Maintenance and troubleshooting

### 6.1 Error conditions, troubleshooting

See chapter "5. Programming" on page 23.

### 6.2 Maintenance

The sensor is maintenance-free.

### 6.3 Repair

Repairs of the sensor may be performed only by MTS Sensors or a repair facility explicitly authorized by MTS Sensors. For return see chapter "2.6 Return" on page 4.

### 6.4 List of spare parts

No spare parts are available for this sensor.

### 6.5 Transport and storage

The conditions of transport and storage of the sensor match the operating conditions mentioned in this document.

## 7. Removal from service / dismantling

The product contains electronic components and must be disposed of in accordance with the local regulations.

## 8. Technical data

### 8.1 Technical data Temposonics® RP5

Output							
Analog	Voltage: 0...10 /10...0/-10...+10/+10...-10 VDC (min. controller load > 5 kΩ) Current: 4(0)...20/20...4(0) mA (min./max. load 0/500 Ω)						
Measured output variables	Position for one or two position magnets Position + speed (without direction) or velocity (with direction) for one position magnet Position for one position magnet + temperature inside the sensor electronics housing						
Measurement parameters							
Position measurement							
Null/Span adjustment	100 % of electrical stroke						
Resolution	16 bit (internal resolution 0.1 μm)						
Linearity deviation <sup>4</sup>	< ±0.01 % F.S. (minimum ±50 μm)						
Repeatability	< ±0.001 % F.S. (minimum ±1 μm)						
Hysteresis	< 4 μm						
Update time	Stroke length	≤ 200 mm	≤ 350 mm	≤ 1200 mm	≤ 2400 mm	≤ 4800 mm	≤ 6350 mm
	Update time	0.25 ms	0.333 ms	0.5 ms	1.0 ms	2.0 ms	5.0 ms
Velocity measurement							
Range	0.01...10 m/s or 1...400 in./s						
Deviation	≤ 0.05 %						
Resolution	16 bit (minimum 0.01 mm/s)						
Operating conditions							
Operating temperature	-40...+85 °C (-40...+185 °F)						
Humidity	90 % relative humidity, no condensation						
Temperature coefficient	< 30 ppm/K						
Ingress protection	IP67 (connectors correctly fitted)/IP68 for cable output						
Shock test	150 g/11 ms, IEC standard 60068-2-27						
Vibration test	30 g/10...2000 Hz, IEC standard 60068-2-6 (excluding resonant frequencies)						
EMC test	Electromagnetic emission according to EN 61000-6-3						
	Electromagnetic immunity according to EN 61000-6-2 The sensor meets the requirements of the EC directives and is marked with <b>CE</b> .						
Magnet movement velocity	Magnet slider: Max. 10 m/s; U-magnet: Any; block magnet: Any						
Design / Material							
Sensor electronics housing	Aluminum (painted), zinc die cast						
Sensor profile	Aluminum						
Stroke length	25...6350 mm (1...250 in.)						
Mechanical mounting							
Mounting position	Any						
Mounting instruction	Please consult the technical drawings on <a href="#">page 11</a>						
Electrical connection							
Connection type	1 × M16 male connector (6 pin) or cable output						
Operating voltage	+12...30 VDC ±20 % (9.6...36 VDC)						
Power consumption	< 3.25 W						
Dielectric strength	500 VDC (DC ground to machine ground)						
Polarity protection	Up to -36 VDC						
Overvoltage protection	Up to 36 VDC						

4/ With position magnet # 251 416-2

## 8.2 Technical data Temposonics® RH5

Output							
Analogue	Voltage: 0...10 /10...0/-10...+10/+10...-10 VDC (min. controller load > 5 kΩ) Current: 4(0)...20/20...4(0) mA (min./max. load 0/500 Ω)						
Measured output variables	Position for one or two position magnets Position + speed (without direction) or velocity (with direction) for one position magnet Position for one position magnet + temperature inside the sensor electronics housing						
Measurement parameters							
Position measurement							
Null/Span adjustment	100 % of electrical stroke						
Resolution	16 bit (internal resolution 0.1 μm)						
Linearity deviation <sup>5</sup>	< ±0.01 % F.S. (minimum ±50 μm)						
Repeatability	< ±0.001 % F.S. (minimum ±1 μm)						
Hysteresis	< 4 μm						
Update time	Stroke length	≤ 200 mm	≤ 350 mm	≤ 1200 mm	≤ 2400 mm	≤ 4800 mm	≤ 7620 mm
	Update time	0.25 ms	0.333 ms	0.5 ms	1.0 ms	2.0 ms	5.0 ms
Velocity measurement							
Range	0.01...10 m/s or 1...400 in./s						
Deviation	≤ 0.05 %						
Resolution	16 bit (minimum 0.01 mm/s)						
Operating conditions							
Operating temperature	-40...+85 °C (-40...+185 °F)						
Humidity	90 % relative humidity, no condensation						
Temperature coefficient	< 30 ppm/K						
Ingress protection	IP67 (connectors correctly fitted)/IP68 for cable output						
Shock test	150 g/11 ms, IEC standard 60068-2-27						
Vibration test	30 g/10...2000 Hz, IEC standard 60068-2-6 (excluding resonant frequencies)/ RH5-J: 15 g / 10...2000 Hz, IEC standard 60068-2-6 (excluding resonant frequencies)						
EMC test	Electromagnetic emission according to EN 61000-6-3 Electromagnetic immunity according to EN 61000-6-2 The sensor meets the requirements of the EC directives and is marked with <b>CE</b> .						
Operating pressure	350 bar (5,070 psi)/700 bar (10,150 psi) peak (at 10 × 1 min) for sensor rod/RH5-J: 800 bar (11,600 psi)						
Magnet movement velocity	Any						
Design / Material							
Sensor electronics housing	Aluminum (painted), zinc die cast						
Sensor flange	Stainless steel 1.4305 (AISI 303)/RH5-J: Stainless steel 1.4305 (AISI 303)						
Sensor rod	Stainless steel 1.4306 (AISI 304L)/RH5-J: Stainless steel 1.4301 (AISI 304)						
Stroke length	25...7620 mm (1...300 in.)/RH5-J: 25...5900 mm (1...232 in.)						
Mechanical mounting							
Mounting position	Any						
Mounting instruction	Please consult the technical drawings on <a href="#">page 12</a>						
Electrical connection							
Connection type	1 × M16 male connector (6 pin) or cable output						
Operating voltage	+12...30 VDC ±20 % (9.6...36 VDC)						
Power consumption	< 3.25 W						
Dielectric strength	500 VDC (DC ground to machine ground)						
Polarity protection	Up to -36 VDC						
Overvoltage protection	Up to 36 VDC						

## 9. Appendix I

### Safety declaration

Dear Customer,

If you return one or several sensors for checking or repair, we need you to sign a safety declaration. The purpose of this declaration is to ensure that the returned items do not contain residues of harmful substances and/or that people handling these items will not be in danger.

MTS Sensors order number: \_\_\_\_\_ Sensor type(s): \_\_\_\_\_

Serial number(s): \_\_\_\_\_ Sensor length(s): \_\_\_\_\_

#### The sensor has been in contact with the following materials:

Do not specify chemical formulas.  
Please include safety data sheets of the substances, if applicable.

In the event of suspected penetration of substances into the sensor, consult MTS Sensors to determine measures to be taken before shipment.

#### Short description of malfunction:

#### Corporate information

Company: \_\_\_\_\_

Address: \_\_\_\_\_

\_\_\_\_\_

#### Contact partner

Name: \_\_\_\_\_

Phone: \_\_\_\_\_

E-mail: \_\_\_\_\_

We hereby certify that the measuring equipment has been cleaned and neutralized.  
Equipment handling is safe. Personnel exposure to health risks during transport and repair is excluded.

Stamp

Signature

Date

#### GERMANY

**MTS Sensor Technologie GmbH & Co. KG**  
Auf dem Schüffel 9  
58513 Lüdenscheid, Germany  
Tel. +49-23 51-95 87 0  
Fax. +49-23 51-5 64 91  
info.de@mtssensors.com  
www.mtssensors.com

#### USA

**MTS Systems Corporation Sensors Division**  
3001 Sheldon Drive  
Cary, N.C. 27513, USA  
Tel. +1 919 677-0100  
Fax +1 919 677-0200  
info.us@mtssensors.com  
www.mtssensors.com

## 10. Appendix II

### CYLINDER PORT DETAILS

#### PORT DETAIL (PD) FOR RH5-S:

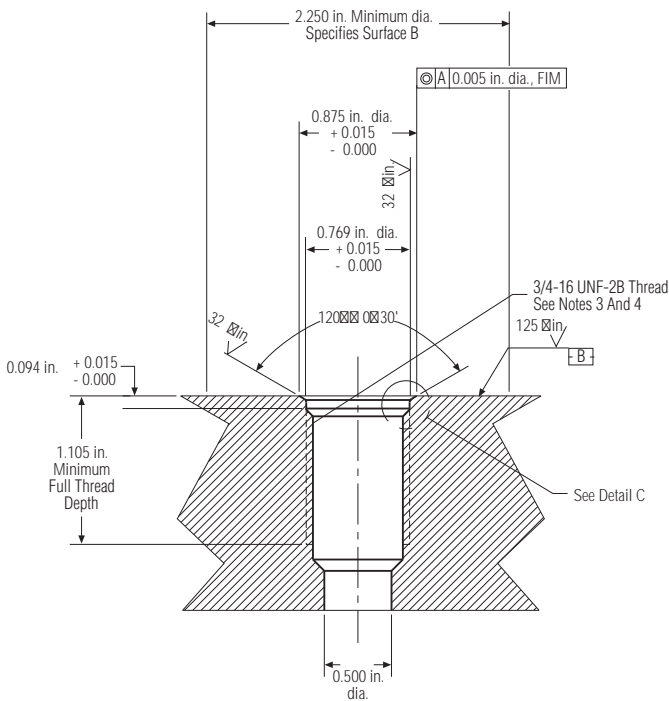

#### NOTES:

1. Dimensions and tolerances based on ANSI Y14.5-1982.
2. MTS has extracted all pertinent information from MS33649 to generate this document.
3. PD must be square with surface B within 0.005 FIM across 2.250 dia minimum.
4. PD must be concentric with 2.250 dia within 0.030 FIM and with 0.769 dia within 0.005 FIM.
5. Surface texture ANSI B46.1-1978
6. Use O-ring MTS part number 560315 for correct sealing.
7. The thread design shall have sufficient threads to meet strength requirements of material used.
8. Finish counter-bore shall be free from longitudinal and spiral tool marks. Annular tool marks up to 32 microinches maximum will be permissible.

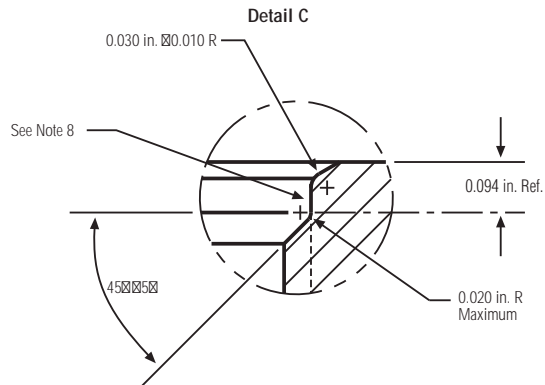

#### PORT DETAIL (PD) FOR RH5-T:

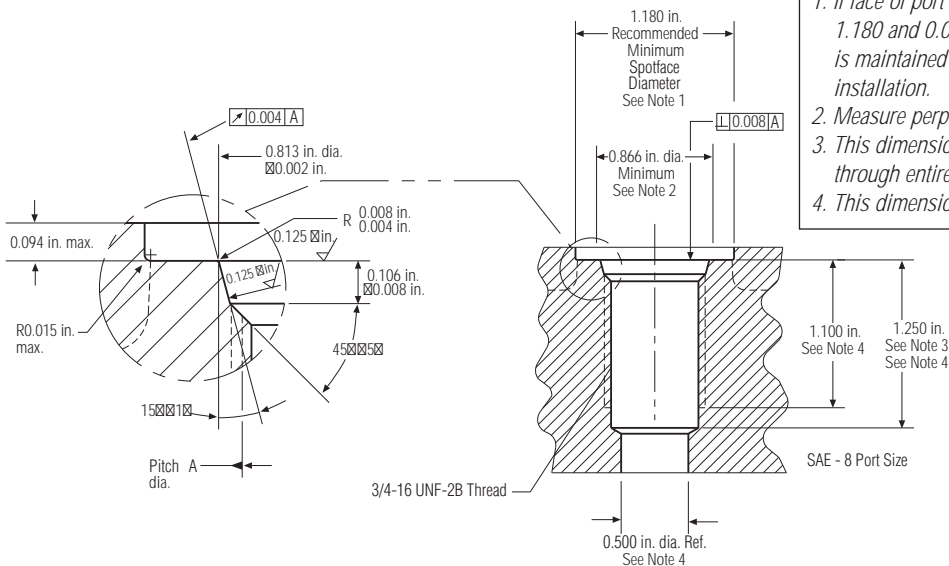

#### NOTES:

1. If face of port is on a machined surface, dimensions 1.180 and 0.094 need not apply as long as R0.008/0.004 is maintained to avoid damage to the O-ring during installation.
2. Measure perpendicularity to A at this diameter.
3. This dimension applies when tap drill cannot pass through entire boss.
4. This dimension does not conform to SAE J1926/1.

## 11. Glossary

<b>A</b>
<p><b>Analog output</b> For a sensor with analog output, the measured value is output as an analog voltage signal or current signal.</p>
<b>D</b>
<p><b>Differential</b> For differential measurement, the distance between the two position magnets is output as a value.</p>
<b>M</b>
<p><b>Max speed or velocity value</b> For speed or velocity, the output value generated is scaled based on the maximum speed or velocity value indicated in the order code.</p>
<p><b>Measuring direction</b></p> <ul style="list-style-type: none"> <li>• Forward: Values increasing from sensor electronics housing to rod end/profile end</li> <li>• Reverse: Values decreasing from sensor electronics housing to rod end/profile end</li> </ul>
<p><b>Multi-position measurement</b> During the measurement cycle, the positions of every magnet on the sensor are simultaneously reported. The velocity or speed are continuously calculated based on these changing position values as the magnets are moved.</p>
<b>O</b>
<p><b>Over range output mode</b> When enabled this mode allows the position output values to continue to increase or decrease when the magnet travels beyond the active stroke range.</p>
<b>R</b>
<p><b>Resolution</b> The sensor precisely measures time to provide the position measurement. For the analog output the measured time value is converted into an analog voltage signal or current signal using a high-performance Digital to Analog Converter (DAC) having 16 bits of resolution.</p>
<b>S</b>
<p><b>Speed</b> The output value for speed indicates how fast the position magnet is being moved, independent of the measuring direction. (→ Velocity)</p>
<b>T</b>
<p><b>Temperature inside the sensor electronics housing</b> The temperature inside the sensor electronics housing is reported as an analog voltage signal or current signal. For each output range, the 0 % output value has the factory default setpoint at -40 °C, and the 100 % output value has the default setpoint at +100 °C. Note: a dedicated temperature chip is used for the output signal and its values may vary from those reported on the TempoLink application screen.</p>
<b>V</b>
<p><b>Velocity</b> The output value for velocity indicates how fast the position magnet is being moved, and in which direction. (→ Speed)</p>

**UNITED STATES** 3001 Sheldon Drive  
MTS Systems Corporation Cary, N.C. 27513  
Sensors Division Phone: +1 919 677-0100  
Americas & APAC Region E-mail: info.us@mtssensors.com

---

**GERMANY** Auf dem Schüffel 9  
MTS Sensor Technologie 58513 Lüdenscheid  
GmbH & Co. KG Phone: +49 2351 9587-0  
EMEA Region & India E-mail: info.de@mtssensors.com

---

**ITALY** Phone: +39 030 988 3819  
Branch Office E-mail: info.it@mtssensors.com

---

**FRANCE** Phone: +33 1 58 4390-28  
Branch Office E-mail: info.fr@mtssensors.com

---

**UK** Phone: +44 79 44 15 03 00  
Branch Office E-mail: info.uk@mtssensors.com

---

**SCANDINAVIA** Phone: +46 70 29 91 281  
Branch Office E-mail: info.sca@mtssensors.com

---

**CHINA** Phone: +86 21 2415 1000 / 2415 1001  
Branch Office E-mail: info.cn@mtssensors.com

---

**JAPAN** Phone: +81 3 6416 1063  
Branch Office E-mail: info.jp@mtssensors.com

---

**Document Part Number:**  
552063 Revision B (EN) 04/2021



[www.mtssensors.com](http://www.mtssensors.com)