

Operation Manual

E-Series Embedded Analog

Magnetostrictive Linear Position Sensors



Table of contents

1. Introduction	2
1.1 Purpose and use of this manual	2
1.2 Used symbols and warnings.....	2
2. Safety instructions	2
2.1 Intended use.....	2
2.2 Installation, commissioning and operation.....	3
2.3 Safety instructions for use in explosion-hazardous areas.....	3
2.4 Warranty.....	3
2.5 Return	3
3. Identification	4
3.1 Order structure.....	4
3.2 Nameplate (example).....	5
3.3 Approvals	5
3.4 Scope of delivery.....	5
4. Product description and commissioning	5
4.1 Functionality and system design.....	5
4.2 Styles and installation.....	6
4.3 Electrical connection.....	9
4.4 Accessories	10
5. Operation	12
5.1 Getting started.....	12
5.2 Programming and configuration.....	12
5.3 Configuration example.....	12
6. Maintenance and troubleshooting	12
6.1 Error conditions, troubleshooting.....	12
6.2 Maintenance	12
6.3 Repair.....	12
6.4 List of spare parts.....	12
7. Removal from service/dismantling	12
7.1 Disposal.....	12
8. Technical data	13
8.1 Input.....	13
8.2 Output	13
8.3 Performance.....	13
8.4 Operating conditions	13
8.5 Design and material.....	13
8.6 Installation.....	13
8.7 Power supply.....	13
8.8 Electrical connection.....	13
9. Annex	14
Return sheet.....	14

1. Introduction

1.1 Purpose and use of this manual

Before starting the operation of Temposonics® sensors, please, read this documentation thoroughly and follow the safety information.

The content of this technical documentation and of its various annexes is intended to provide quick information on mounting, installation and commissioning by qualified automation personnel ¹ or instructed service technicians who are familiar with the project planning and dealing with Temposonics® sensors.

1.2 Used symbols and warnings

Warnings are intended for your personal safety and for avoidance of damage to the described product or connected devices. In this documentation, safety information and warnings to avoid dangers that might affect the life and health of operating or service personnel or cause material damage are highlighted by the preceding pictogram, which is defined below.

Symbol	Meaning
NOTICE	This symbol is used to point to situations that may lead to material damage, but not to personal injury.

2. Safety instructions

2.1 Intended use

This product may be used only for the applications provided in the technical description and only in conjunction with third-party devices and components recommended or approved by Temposonics. As a prerequisite of proper and safe operation, the product requires correct transport, storage, mounting and commissioning and must be operated with utmost care.

- The sensor systems of all Temposonics® series are intended exclusively for measurement tasks encountered in industrial, commercial and laboratory applications. The sensors are considered as system accessories and must be connected to suitable evaluation electronics, e.g. a PLC, IPC, indicator or other electronic control unit.
- The position sensors must be used only in technically safe condition. To maintain this condition and to ensure safe operation, installation, connection and service work may be performed only by qualified technical personnel.

^{1/} The term „qualified technical personnel“ characterizes persons who:
 - are familiar with the safety concepts of automation technology applicable to the particular project.
 - are competent in the field of EMC

^{1/} - have received adequate training for commissioning and service operations
 - are familiar with the operation of the device and know the information required for correct operation provided in the product documentation.

2.2 Installation, commissioning and operation

If danger of injury to persons or of damage to operating equipment is caused by sensor failure or malfunction, additional safety measures such as plausibility checks, limit switches, EMERGENCY OFF systems, protective devices etc. are required. In the event of trouble, shut down the sensor and protect it against accidental operation.

Installation, operation

To maintain the sensor operability, it is mandatory to follow the instructions given below.

1. Protect the sensor against mechanical damage during installation and operation.
2. Do not open or dismantle the sensor.
3. Connect the sensor very carefully and pay attention to the polarity of connections, power supply as well as to the shape and duration of control pulses.
4. Use only approved power supplies.
5. It is indispensable to ensure that the specified permissible limit values of the sensor for supply voltage, environmental conditions, etc. are met.
6. Check the function of the sensor regularly and provide documentation of the checks.
7. Before system switch-on, ensure that nobody's safety is jeopardized by starting machines.

2.3 Safety instructions for use in explosion-hazardous areas

The sensor is not suitable for operation in explosion-hazardous areas.

2.4 Warranty ²

Temposonics grants a warranty period for the Temposonics® position sensors and supplied accessories relating to material defects and faults that occur despite correct use in accordance with the intended application ². The Temposonics obligation is limited to repair or replacement of any defective part of the unit. No warranty can be taken for defects that are due to improper use or above average stress of the product, as well as for wear parts. Under no circumstances will Temposonics accept liability in the event of offense against the warranty rules, no matter if these have been assured or expected, even in case of fault or negligence of the company. Temposonics explicitly excludes any further warranties. Neither the company's representatives, agents, dealers nor employees are authorized to increase or change the scope of warranty.

2.5 Return

For diagnostic purposes, the sensor can be returned to Temposonics GmbH. Any shipment cost will be borne by the sender ². A corresponding return form is included in annex.

^{2/} see also applicable Temposonics Sales and Supply Conditions, e.g. under www.temposonics.com

3. Identification

3.1 Order structure

1	2	3	4	5	6	7	8	9	10	11	12	13	14	15
E	E	S									1			
a		b	c					d			e	f		

a	Sensor model	
E	E	Rod

b	Design	
S	Pressure fit flange, 10 mm rod-Ø	

c	Stroke length				
X	X	X	X	M	0050...2540 mm
X	X	X	X	U	002.0...100.0 in.

Standard stroke length (mm)*

Stroke length	Ordering steps
50... 500 mm	5 mm
500... 750 mm	10 mm
750...1000 mm	25 mm
1000...2540 mm	50 mm

Standard stroke length (in.)*

Stroke length	Ordering steps
2... 20 in.	0.2 in.
20... 30 in.	0.5 in.
30... 40 in.	1.0 in.
40...100 in.	2.0 in.

d	Connection type		
M	1	1	6 pin molex PicoBlade™ connector system Cable length 110 mm
M	3	1	6 pin molex PicoBlade™ connector system Cable length 310 mm
M	6	1	6 pin molex PicoBlade™ connector system Cable length 610 mm

e	Operating voltage	
1	+24 VDC (-15 / +20 %)	

f	Output		
A	0	1	4...20 mA
A	1	1	20...4 mA

3.2 Nameplate (example)

Order code (Part no.)	EE X XXXXX XXX X XX
Coding depending on output	XXXXXXXX
Serial no.	FNr. 1320 0376

3.3 Approvals

The sensor conforms to the EU directives and is provided with CE marking.

3.4 Scope of delivery

Sensor with installed back-up ring and O-ring.

4. Product description and commissioning

4.1 Functionality and system design

Product designation

- Position sensor Temposonics® E-Series

Construction series

- Temposonics® EE (rod-shaped housing)
- Stroke length 50...2540 mm
- Output signal: analog

Application

The Temposonics® sensor is used for measurement and conversion of the position variable in the field of automated system and mechanical engineering.

Principle of operation and system construction

For position measurement, the absolute, linear Temposonics® position sensors make use of the properties offered by the specially designed magnetostrictive waveguide. Inside the sensor a torsional strain pulse is induced in the waveguide by momentary interaction of two magnetic fields. One field is produced by a moving position magnet, which travels along the outside of the sensor element. The other field is generated by a current pulse applied to the waveguide.

The interaction between these two magnetic fields produces a strain pulse, which is detected at the head of the sensor. The position of the moving magnet is determined precisely by measuring the time elapsed between the application of the current pulse and the arrival of the strain pulse. The result is a reliable position measurement system capable of ensuring accurate and repeatable measurement.

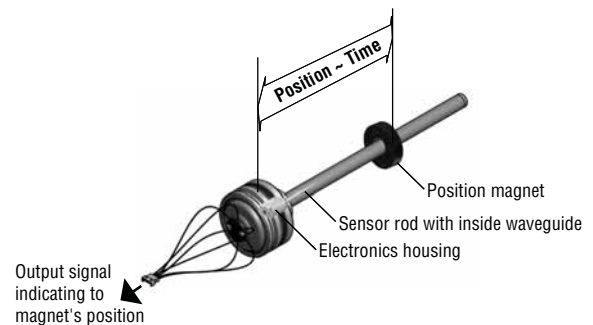

Fig. 1: Principle of operation:

Magnetostrictive runtime measurement = position information

Modular mechanical and electronic construction

- The sensor rod protects the inside sensing element (waveguide).
- The electronics housing accommodates the complete electronic interface with active signal conditioning.
- The external position magnet is a permanent magnet. Mounted on the mobile machine part, it travels along the sensor and triggers the measurement through the wall of the sensor rod housing.
- The sensor can be connected directly to a control system. Its electronics generates a strictly position-proportional signal output between zero and end position.

4.2 Styles and installation

The pressure-resistant stainless steel rod is installed in the hydraulic cylinder under reduced space conditions. The position is measured contactlessly via a ring-shaped position magnet.

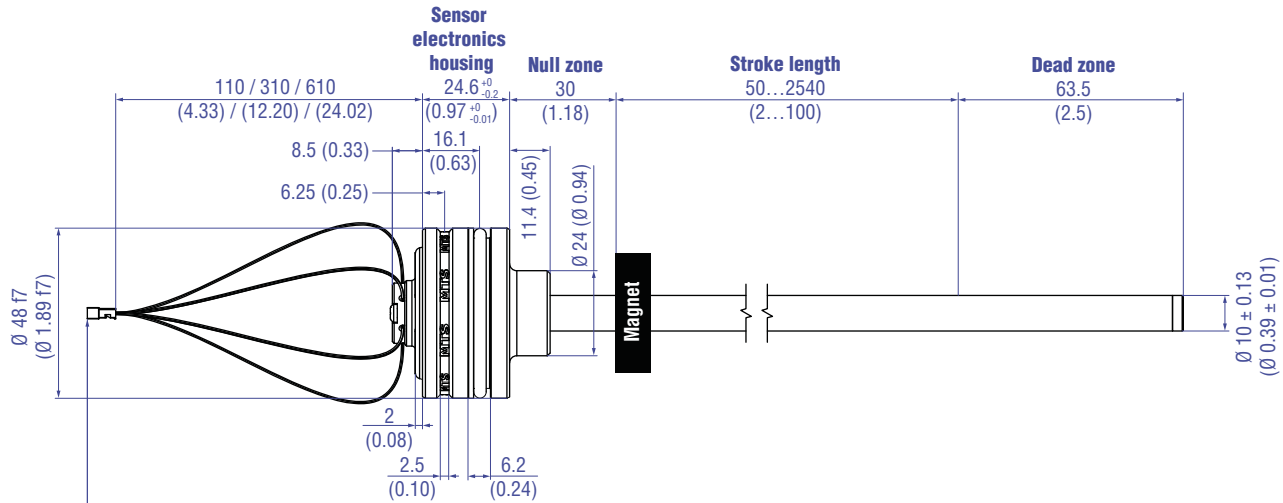

6 pin molex PicoBlade™ connector system molex grid = 1.25
 Unless otherwise stated, apply to the general tolerances according to DIN ISO 2768-m

Fig. 2: Temposonics® EE

Active measuring range

The technical data of each sensor is checked as well as documented and the active measuring range (useful electrical stroke) with its span start and end (see Fig. 3) is adjusted during final inspection and testing.

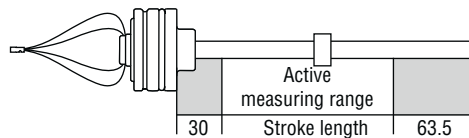

Fig. 3: Active measuring range

NOTICE

On all sensors, the areas left and right of the active measuring range are provided for mounting and damping of the measuring signal. They should not be used for measurement, but the active measuring range can be exceeded without problem.

Mechanical zero

To ensure that the entire measuring range can be used electrically, the position magnet must be mounted mechanically as follows (see Fig. 4).

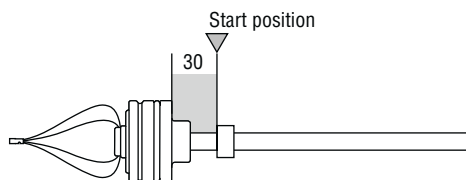

Fig. 4: Temposonics® rod with ring magnet

Installation in a hydraulic cylinder

The mounting method is determined exclusively by the cylinder construction (Fig. 5). In most cases, the installation is performed from the side of the piston rod. However, installation from the piston side of the cylinder is also possible. In both cases, sealing of the cylinder is ensured by an O-ring and a back-up ring.

NOTICE When installing, please note:

- The position magnet must not drag on the measuring rod.
- The bore hole in the piston rod should be min. 13.5 mm. The specified operating pressures must be observed.

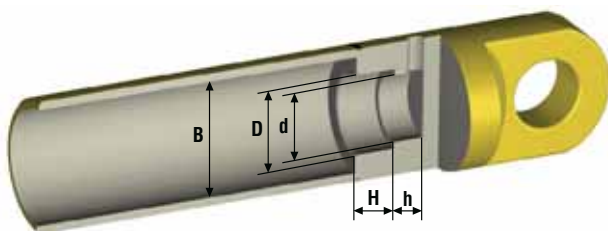

Fig. 5: Rod eye cylinder installation example

Type	B Ø cylinder	D Ø	H Depth	d Ø min.	h Depth
EE	e.g. 52	48	24.6	> 37.5 < 40	> 15

Installing the position magnet in the piston

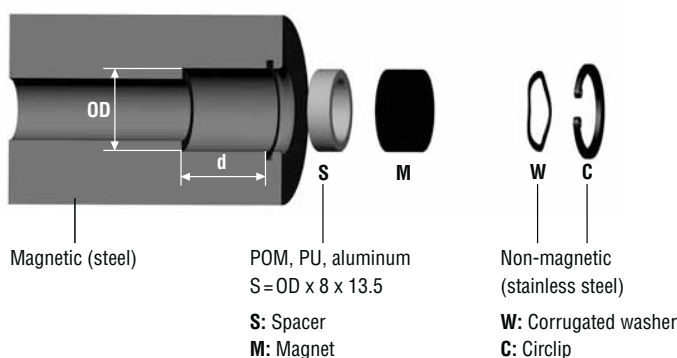

Fig. 6: „Position magnet in piston“ installation example

	Ring magnet OD25,4 Part no.: 400 533	Ring magnet OD33 Part no.: 201 542-2
OD	25.4 mm	33.0 mm
d	min. 16 mm *	min. 16 mm *

All dimensions in mm

*/Without corrugated washer and circlip

O- and back-up ring positioning

O-ring and back-up ring are factory-fitted by Temposonics as shown in Fig. 7.

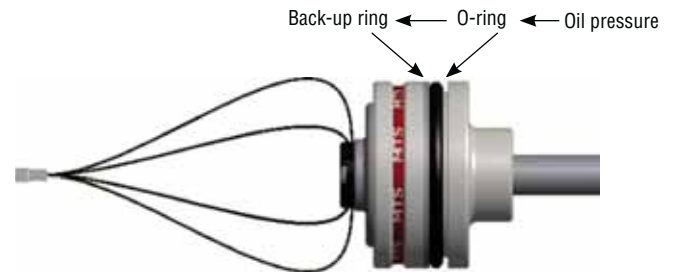

Fig. 7: Positioning of o-rings and back-up rings

Note on safeguarding by means of a threaded pin

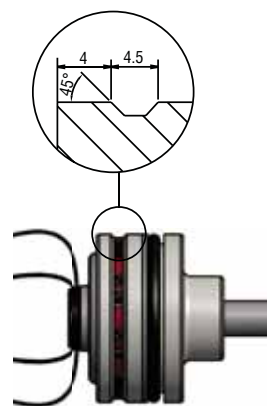
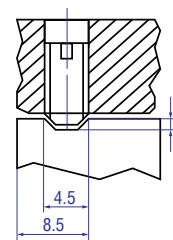

Fig. 8: Flange housing with O-Ring and back-up ring

Fig. 9:
e.g. Safeguarding by means of a threaded pin DIN 913 M5x10 (using a flat point)
max. fastening torque 0.5 Nm



Load-bearing geometries on sensor housings

Only the surfaces marked in green may be loaded when mounting the sensor in the cylinder. Don't exert forces or even hammer strokes on the surfaces marked in red.

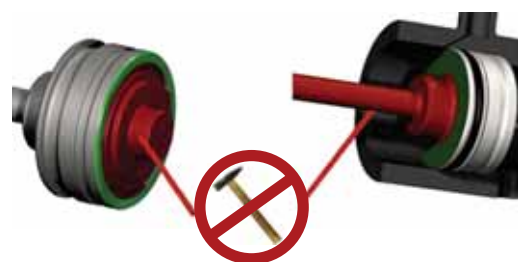
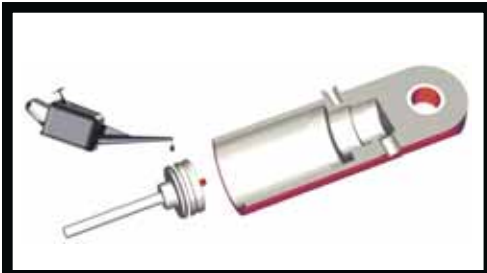

Fig. 10: Load-bearing geometries on sensor housings

Mounting in the cylinder



1 Grease the O-ring and the back-up ring before mounting in the cylinder.



2 Slide the sensor carefully into the seat. Pay attention to connecting wires and cables.

NOTICE

Avoid strain to connecting wires and cables.



3 Use a custom-built bush (e.g. polyamide) to press the sensor into the seat.



4 Only if necessary, drive the sensor home into the seat carefully using a rubber mallet.

NOTICE

Never use a steel hammer. Avoid hard blows on the sensor or on the tools when mounting!

4.3 Electrical connection

Place of installation and cabling have decisive influence on the sensor EMC. Hence correct installation of this active electronic system and the EMC of the entire system must be ensured by using suitable metal connectors, shielded cables and grounding.

Overtages or faulty connections can damage its electronics despite protection against wrong polarity.

Instruction for connection

- Never connect the sensor when under voltage!
- Use low-resistance twisted pair and shielded cables and connect the shield to earth externally via the controller equipment.
- Control and signal leads should be kept separate from power cables and away from motor cables, frequency inverters, valve cables, switching relays, etc.
- Use only metal connectors and connect the shielding to the connector housing.
- Connect the shields at both cable ends via a large surface and connect the cable clamps to function earth.
- Keep all non-shielded leads as short as possible.
- Keep the earth connections short and with a large cross section and avoid ground loops.
- With potential differences between the earth connection of the machine and the electronics, no compensating current flowing over the shield is allowed. We recommend using an equipotential bonding conductor with large cross-section or a cable with separate dual shielding and connecting the shields only at one end.
- Use only stabilized power supplies and ensure that the specified connecting values are met.

CONNECTOR WIRING

With mating connector cable 254 256 and 254 560

5 pin connector	M12	Function
	Pin 1	+24 VDC (-15 / +20 %)
	Pin 2	Output 1
	Pin 3	DC Ground (0 V)
	Pin 4	—
	Pin 5	DC Ground

Fig. 11: Connector wiring with mating connector cable 254 256 and 254 560

With mating connector cable 254 266

6 pin molex connector	Molex	Color	Function
	Pin 1	YE	—
	Pin 2	—	—
	Pin 3	GY	Output 1
	Pin 4	WH	DC Ground (0 V)
	Pin 5	BK	DC Ground
	Pin 6	BN	+24 VDC (-15 / +20 %)

Fig. 12: Connector wiring with mating connector cable 254 266

With extension cable 254 642-x

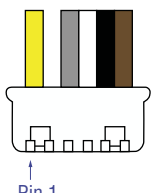

6 pin molex connector	Molex	Color	Function
	Pin 1	YE	—
	Pin 2	BL	—
	Pin 3	GY	Output 1
	Pin 4	WH	DC Ground (0 V)
	Pin 5	BK	DC Ground
	Pin 6	BN	+24 VDC (-15 / +20 %)

Fig. 13: Connector wiring with extension cable 254 642-x

4.4 Accessories

FREQUENTLY ORDERED ACCESSORIES – Additional options available in our [Accessories Guide](#)  [551444](#)

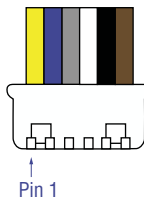
Position magnets

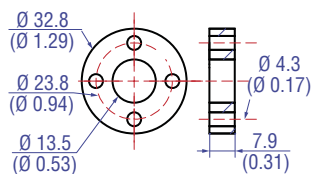

Standard ring magnet
Part no. 201 542-2

Material: PA ferrite GF20
Weight: Ca. 14 g
Operating temperature:
-40...+105 °C (-40...+221 °F)
Surface pressure: Max. 40 N/mm²
Fastening torque for M4 screws: 1 Nm

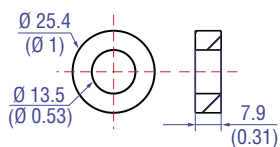

Ring magnet OD25.4
Part no. 400 533

Material: PA ferrite
Weight: Ca. 10 g
Operating temperature:
-40...+105 °C (-40...+221 °F)
Surface pressure: Max. 40 N/mm²

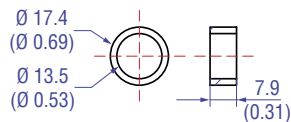

Ring magnet OD17.4
Part no. 401 032

Material: PA neobind
Weight: Ca. 5 g
Operating temperature:
-40...+105 °C (-40...+221 °F)
Surface pressure: Max. 20 N/mm²

Cable connectors³

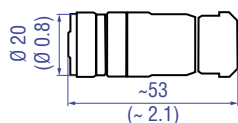

Female, straight, 5 pin, M12
Part no. 370 677

Housing: GD-Zn, Ni / IP67
Termination: Screw; max. 0.75 mm²
Contact insert: CuZn
Cable Ø: 4...8 mm (0.16...0.31 in.)
Fastening torque: 0.6 Nm

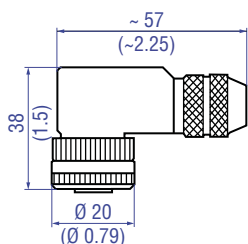

Female, angled, 5 pin, M12
Part no. 370 678

Housing: GD-Zn, Ni / IP67
Termination: Screw; max. 0.75 mm²
Contact insert: CuZn
Cable Ø: 5...8 mm (0.2...0.31 in.)
Fastening torque: 0.6 Nm

³ Controlling design dimensions are in millimeters and measurements in () are in inches

³ Follow the manufacturer's mounting instructions when connecting the connectors

Mating connector cables

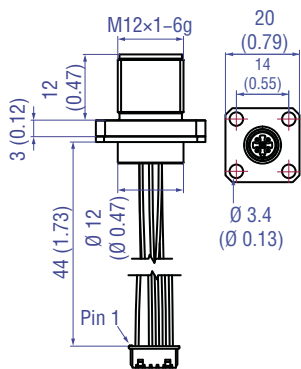

5 pin mating connector cable M12
Part no. 254 256

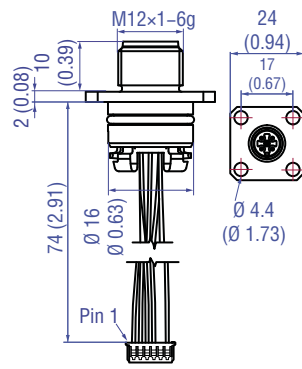

5 pin mating connector cable M12
Part no. 254 560

More informationen see [551758](#)

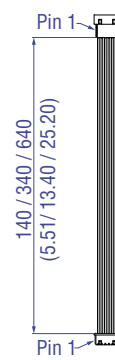

Extension cable molex to molex
140 mm: Part no. 254 642-1
340 mm: Part no. 254 642-2
640 mm: Part no. 254 642-3

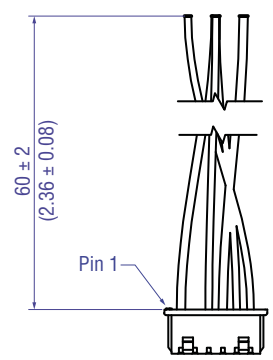

Mating connector cable pigtail
Part no. 254 266

5. Operation

5.1 Getting started

1. Before initial switch-on, check carefully if the sensor has been connected correctly.
2. Ensure that the sensor control system cannot be displaced in an uncontrolled way when switching on.
3. After switching on, the sensor is ready for operation and in operating mode.
4. Check the preset span start and end values (see section 4.2).

5.2 Programming and configuration

The sensor is factory-set and adjusted to its ordering variables, i.e. the required output signal corresponds exactly to the selected stroke length.

Example: output 4...20 mA = 0...100 % stroke length

5.3 Configuration example

Omitted.

6. Maintenance and troubleshooting

6.1 Error conditions, troubleshooting

The sensor doesn't send a position signal – Check the supply voltage.

6.2 Maintenance

The sensor is maintenance-free.

6.3 Repair

Repairs on the sensor may be performed only by Temposonics or an explicitly authorized body.

6.4 List of spare parts

Omitted.

7. Removal from service / dismantling

7.1 Disposal

The product contains electronic components and must be disposed of in accordance with the local regulations.

8. Technical data

8.1 Input

Measured value	position
Stroke length	50...2540 mm

8.2 Output

1. Current	4...20 mA or 20...4 mA (min/max. load: 0/500 Ohms)
------------	--

8.3 Performance

Resolution	infinite
Linearity ⁴	$\leq \pm 0.02$ % F.S. (minimum ± 60 μ m)
Repeatability	$\leq \pm 0.002$ % F.S. (minimum ± 20 μ m)
Sample rate	≤ 3 kHz
Ripple	≤ 0.01 % F.S.

8.4 Operating conditions

Mounting position	any
Magnet movement velocity	any
Operating temperature	-40 °C...+85 °C
Dew point, humidity	90 % rel. humidity, no condensation
Ingress protection	IP67 (with professional mounted housing and connectors), sensor with flat connector IP30
Shock test	100 g (single shock) IEC-Standard 60068-2-27
Vibration test	15 g / 10...2000 Hz IEC-Standard 60068-2-6 (resonance frequencies excluded)
EMC test	Electromagnetic emission EN 55011, cl. B:2009 + A1:2010 Electromagnetic immunity EN 61326-1:2006

8.5 Design and material

Electronics housing	stainless steel 1.4301 / AISI 304
Rod	stainless steel 1.4301 / AISI 304 10 mm rod: 350 bar, 530 bar peak
Position magnet	ring magnet, PA-Ferrite

8.6 Installation

Mounting type	embedded
Mounting position	any

8.7 Power supply

Supply voltage	24 VDC (+20 % / -15 %)
Current consumption	50...140 mA
Ripple	≤ 0.28 Vpp

8.8 Electrical connection

Connection type	6 pin molex
Dielectric strength	500 VDC (0 V ground to machine ground)
Polarity protection	up to -30 VDC
Overvoltage protection	up to 36 VDC

⁴/ with position magnet # 201 542-2

9. Anhang

Safety Declaration

Dear Customer,

If you return one or several for checking or repair, we need you to sign a safety declaration. The purpose of this declaration is to ensure that the returned items do not contain residues of harmful substances and / or that any danger to persons when handling these items is excluded.

Temposonics order _____ Sensor type(s): _____

number: Serial number(s): _____ Sensor length: _____

The sensor has been in contact with the following materials:

Don't specify chemical formulas.
Please, include safety data sheets of the substances, if applicable.

In the event of suspected penetration of substances into the sensor, consult Temposonics to determine measures to be taken before shipment, if necessary.

Short description of malfunction:

Corporate information

Company: _____

Address: _____

Contact partner

Name: _____

Phone: _____

E-Mail: _____

We hereby certify that the measuring equipment has been cleaned and neutralized. Equipment handling is safe. Personnel exposure to health risks during transport and repair is excluded.

Stamp

Signature

Date

Temposonics GmbH & Co.KG
Auf dem Schüffel 9
58513 Lüdenscheid, Germany

Tel. +49-23 51-95 87 0
Fax +49-23 51-5 64 91
info@temposonics.com
www.temposonics.com

UNITED STATES
Temposonics, LLC.
Americas & APAC Region
3001 Sheldon Drive
Cary, N.C. 27513
Phone: +1 919 677-0100
E-mail: info.us@temposonics.com

GERMANY
Temposonics
GmbH & Co. KG
EMEA Region & India
Auf dem Schüffel 9
58513 Lüdenscheid
Phone: +49 2351 9587-0
E-mail: info.de@temposonics.com

ITALY
Branch Office
Phone: +39 030 988 3819
E-mail: info.it@temposonics.com

FRANCE
Branch Office
Phone: +33 1 58 4390-28
E-mail: info.fr@temposonics.com

UK
Branch Office
Phone: +44 79 44 15 03 00
E-mail: info.uk@temposonics.com

SCANDINAVIA
Branch Office
Phone: +46 70 29 91 281
E-mail: info.sca@temposonics.com

CHINA
Branch Office
Phone: +86 21 2415 1000 / 2415 1001
E-mail: info.cn@temposonics.com

JAPAN
Branch Office
Phone: +81 3 6416 1063
E-mail: info.jp@temposonics.com

Document Part Number:
551415 Revision B (EN) 03/2016



temposonics.com