

Operation Manual

GB-Series Analog

Magnetostriktive Lineare Positionssensoren



Table of contents

1. Introduction	3
1.1 Purpose and use of this manual	3
1.2 Used symbols and warnings	3
2. Safety instructions	3
2.1 Intended use	3
2.2 Foreseeable misuse	3
2.3 Installation, commissioning and operation	4
2.4 Safety instructions for use in explosion-hazardous areas	4
2.5 Warranty	4
2.6 Return	4
3. Identification	5
3.1 Order code Temposonics® GB	5
3.2 Nameplate (example)	6
3.3 Approvals	6
3.4 Scope of delivery	6
4. Product description and commissioning	6
4.1 Functionality and system design	6
4.2 Styles and installation of Temposonics® GB-J / GB-K / GB-N / GB-S	7
4.3 Styles and installation of Temposonics® GB-M / GB-T / GB-B	9
4.4 Magnet installation	11
4.5 Change orientation of sensor electronics housing	13
4.6 Replacement of base unit	13
4.7 Electrical connection	14
4.8 Frequently ordered accessories	15
5. Operation	17
5.1 Getting started	17
5.2 Programming and configuration	17
5.2.1 Analog hand programmer, part no. 253 124	18
5.2.2 Analog cabinet programmer, part no. 253 408	19
5.2.3 Programming kit, part no. 254 555	20
5.2.4 Setting examples for programming tools	22
6. Maintenance and troubleshooting	22
6.1 Error conditions, troubleshooting	22
6.2 Maintenance	22
6.3 Repair	22
6.4 List of spare parts	22
6.5 Transport and storage	23
7. Removal from service / dismantling	23
8. Technical data	24
8.1 Technical data GB-J / GB-K / GB-N / GB-S	24
8.2 Technical data GB-M / GB-T	25
9. Appendix	26

1. Introduction

1.1 Purpose and use of this manual

Before starting the operation of Temposonics® position sensors read this documentation thoroughly and follow the safety information. Keep the manual for future reference!

The content of this technical documentation and of its appendix is intended to provide information on mounting, installation and commissioning by qualified automation personnel ¹ or instructed service technicians who are familiar with the project planning and dealing with Temposonics® sensors.

1.2 Used symbols and warnings

Warnings are intended for your personal safety and for avoidance of damage to the described product or connected devices. In this documentation, safety information and warnings to avoid dangers that might affect the life and health of operating or service personnel or cause material damage are highlighted by the preceding pictogram, which is defined below.

Symbol	Meaning
NOTICE	This symbol is used to point to situations that may lead to material damage, but not to personal injury.

2. Safety instructions

2.1 Intended use

This product may be used only for the applications defined under item 1 and only in conjunction with the third-party devices and components recommended or approved by MTS Sensors. As a prerequisite of proper and safe operation, the product requires correct transport, storage, mounting and commissioning and must be operated with utmost care.

- The sensor systems of all Temposonics® series are intended exclusively for measurement tasks encountered in industrial, commercial and laboratory applications. The sensors are considered as system accessories and must be connected to suitable evaluation electronics, e.g. a PLC, IPC, indicator or other electronic control unit.

^{1/} The term qualified technical personnel characterizes persons who:

- are familiar with the safety concepts of automation technology applicable to the particular project,
- are competent in the field of electromagnetic compatibility (EMC),

2.2 Foreseeable misuse

Foreseeable misuse	Consequence
Wrong sensor connection	The sensor will not work properly or can be damaged
Operate the sensor out of the operating temperature range	No signal output The sensor can be damaged
Power supply is out of the defined range	Signal output is wrong / no signal output / the sensor can be damaged
Position measurement is influenced by an external magnetic field	Signal output is wrong
Cables are damaged	Short circuit – the sensor can be destroyed / sensor does not respond
Spacers are missing / installed in wrong order	Error in position measurement
Wrong connection of ground / shield	Signal output is disturbed The electronics can be damaged
Use of a magnet that is not certified by MTS Sensors	Error in position measurement

Do not alter the sensor afterwards.
→ The sensor might be damaged.

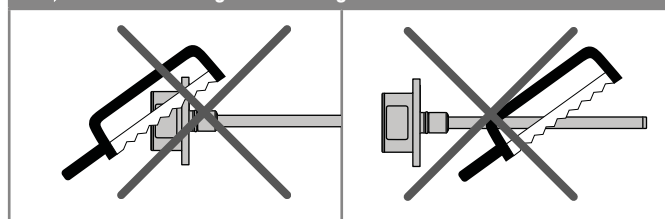

Do not step on the sensor.
→ The sensor might be damaged.

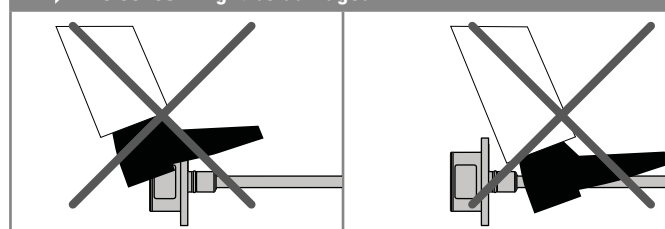

- have received adequate training for commissioning and service operations
- are familiar with the operation of the device and know the information required for correct operation provided in the product documentation.

2.3 Installation, commissioning and operation

The position sensors must be used only in technically safe condition. To maintain this condition and to ensure safe operation, installation, connection and service, work should only be performed by qualified technical personnel.

If danger of injury to persons or of damage to operating equipment is caused by sensor failure or malfunction, additional safety measures such as plausibility checks, limit switches, EMERGENCY STOP systems, protective devices etc. are required. In the event of trouble, shut down the sensor and protect it against accidental operation.

Safety instructions for commissioning

To maintain the sensor's operability, it is mandatory to follow the instructions given below.

1. Protect the sensor against mechanical damage during installation and operation.
2. Do not open or dismantle the sensor.
3. Connect the sensor very carefully and pay attention to the polarity of connections and power supply.
4. Use only approved power supplies.
5. It is indispensable to ensure that the specified permissible limit values of the sensor for operating voltage, environmental conditions, etc. are met.
6. Check the function of the sensor regularly and provide documentation of the checks.
7. Before applying power, ensure that nobody's safety is jeopardized by starting machines.

2.4 Safety instructions for use in explosion-hazardous areas

The sensor is not suitable for operation in explosion-hazardous areas.

2.5 Warranty

MTS Sensors grants a warranty period for the Temposonics® position sensors and supplied accessories relating to material defects and faults that occur despite correct use in accordance with the intended application ². The MTS Sensors obligation is limited to repair or replacement of any defective part of the unit. No warranty can be provided for defects that are due to improper use or above average stress of the product, as well as for wear parts.

Under no circumstances will MTS Sensors accept liability in the event of offense against the warranty rules, no matter if these have been assured or expected, even in case of fault or negligence of the company. MTS Sensors explicitly excludes any further warranties.

Neither the company's representatives, agents, dealers nor employees are authorized to increase or change the scope of warranty.

2.6 Return

For diagnostic purposes, the sensor can be returned to MTS Sensors or a repair facility explicitly authorized by MTS Sensors. Any shipment cost is the responsibility of the sender ². For a corresponding form, see chapter "9. Appendix" on page 27.

^{2/} See also applicable MTS Sensors terms of sales and delivery on www.mtssensors.com

3. Identification

3.1 Order code Temposonics® GB

1	2	3	4	5	6	7	8	9	10	11	12	13	14	15	16
G	B										1				C
a	b	c						d	e	f	g	h			

a	Sensor model
G B	Rod
b	Design
GB with threaded flange	
B	Base unit for threaded flanges »M« and »T« (replacement only)
M	Threaded flange with flat-face, M18×1.5-6g
T	Threaded flange with raised-face, ¾"-16 UNF-3A
GB with pressure fit flange	
J	Housing material stainless steel 1.4305 (AISI 303), rod material stainless steel 1.4301 (AISI 304) Pressure fit flange Ø 21 mm, Ø 12.7 mm rod, 800 bar
K	Housing material stainless steel 1.4305 (AISI 303), rod material stainless steel 1.4306; 1.4307 (AISI 304L) Pressure fit flange Ø 18 mm, Ø 10 mm rod with bushing on rod end
N	Housing material stainless steel 1.4404 (AISI 316L), rod material stainless steel 1.4404 (AISI 316L) ³ Pressure fit flange Ø 18 mm, Ø 10 mm rod
S	Housing material stainless steel 1.4305 (AISI 303), rod material stainless steel 1.4306; 1.4307 (AISI 304L) Pressure fit flange Ø 18 mm, Ø 10 mm rod

c	Stroke length
X X X X M	0025...3250 mm
X X X X U	001.0...128.0 in.
Standard stroke length (mm)*	Ordering steps
25... 500 mm	5 mm
500... 750 mm	10 mm
750...1000 mm	25 mm
1000...2500 mm	50 mm
2500...3250 mm	100 mm
Standard stroke length (in.)*	Ordering steps
1... 20 in.	0.2 in.
20... 30 in.	0.5 in.
30... 40 in.	1.0 in.
40...100 in.	2.0 in.
100...128 in.	4.0 in.

3/ The sensor in stainless steel 1.4404 (AISI 316L) is only available with following option:
S (-40...+90 °C / -40...+194 °F)

*/ Non standard stroke lengths are available; must be encoded in 5 mm / 0.1 in. increments

4/ Encode in meters if using metric stroke length. Encode in feet if using US customary stroke length

d	Connection type
D 3 4	M12 male connector (5 pin) (Note the operating temperature of the connector)
D 6 0	M16 male connector (6 pin) (Note the operating temperature of the connector)
H X X	H01...H10 (1...10 m) ⁴ XX m PUR cable (part no. 530 052) H03...H33 (3...33 ft) ⁴ XX ft PUR cable (part no. 530 052) (Note the operating temperature of the cable)
T X X	T01...T10 (1...10 m) ⁴ XX m Teflon® cable (part no. 530 112) T03...T33 (3...33 ft) ⁴ XX ft Teflon® cable (part no. 530 112)
V X X	V01...V10 (1...10 m) ⁴ XX m Silicone cable (part no. 530 113) V03...V33 (3...33 ft) ⁴ XX ft Silicone cable (part no. 530 113)

e	Operating voltage
1	+24 VDC (-15 / +20 %)

f	Output
V 0	0...10 VDC and 10...0 VDC
A 0	4...20 mA
A 1	20...4 mA
A 2	0...20 mA
A 3	20...0 mA
A 4	4...20 mA and 20...4 mA

g	Operating temperature
H	-40...+100 °C (-40...+212 °F)
S	-40...+90 °C (-40...+194 °F)

h	Programming
C	Via cable

Trademarks and trade names mentioned in this document are those of their respective owners.

3.2 Nameplate (example)

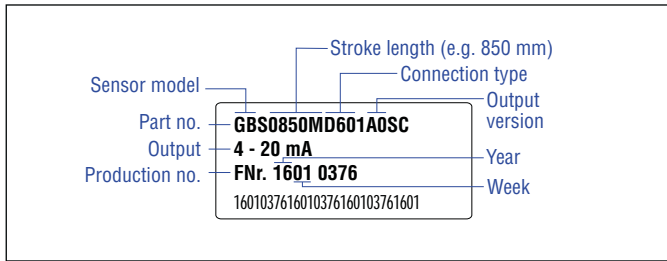

Fig. 1: Example of a nameplate of a GB-S sensor

3.3 Approvals

CE certification

3.4 Scope of delivery

GB-J / GB-K / GB-N / GB-S (rod sensor with pressure fit flange):

- Sensor
- O-ring
- Back-up ring

GB-M / GB-T (rod sensor with threaded flange):

- Sensor
- O-ring

GB-B (base unit for rod sensor with threaded flange):

- Sensor

4. Product description and commissioning

4.1 Functionality and system design

Product designation

- Position sensor Temposonics® GB-Series

Sensor model

- Temposonics® GB-J, GB-K, GB-N, GB-S, GB-M, GB-T (sensor rod)
- Stroke length 25...3250 mm (1...128 in.)

Output signal

- Analog

Application

Temposonics® position sensors are used for measurement and conversion of the length (position) variable in the fields of automated systems and mechanical engineering.

Principle of operation and system construction

The absolute, linear position sensors provided by MTS Sensors rely on the company's proprietary Temposonics® magnetostrictive technology, which can determine position with a high level of precision and robustness. Each Temposonics® position sensor consists of a ferromagnetic waveguide, a position magnet, a strain pulse converter and supporting electronics. The magnet, connected to the object in motion in the application, generates a magnetic field at its location on the waveguide. A short current pulse is applied to the waveguide. This creates a momentary radial magnetic field and torsional strain on the waveguide. The momentary interaction of the magnetic fields releases a torsional strain pulse that propagates the length of the waveguide. When the ultrasonic wave reaches the end of the waveguide it is converted into an electrical signal. Since the speed of the ultrasonic wave in the waveguide is precisely known, the time required to receive the return signal can be converted into a linear position measurement with both high accuracy and repeatability.

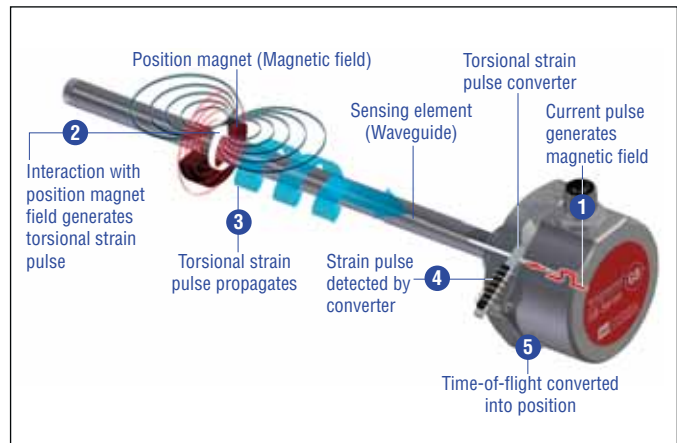

Fig. 2: Time-of-flight based magnetostrictive position sensing principle

Modular mechanical and electronic construction

- The sensor rod protects the inner sensor element.
- The sensor electronics housing, a rugged stainless steel construction, contains the complete electronic interface with active signal conditioning.
- The external position magnet is a permanent magnet. Mounted on the mobile machine part, it travels along the sensor rod and triggers the measurement through the sensor rod wall.
- The sensor can be directly connected to a control system. Its electronics generates a position signal output proportional to the start and end of the active measuring range.

4.2 Styles and installation of Temposonics® GB-J / GB-K / GB-N / GB-S (rod sensor with pressure fit flange)

GB-N / GB-S, example: With M12 connector

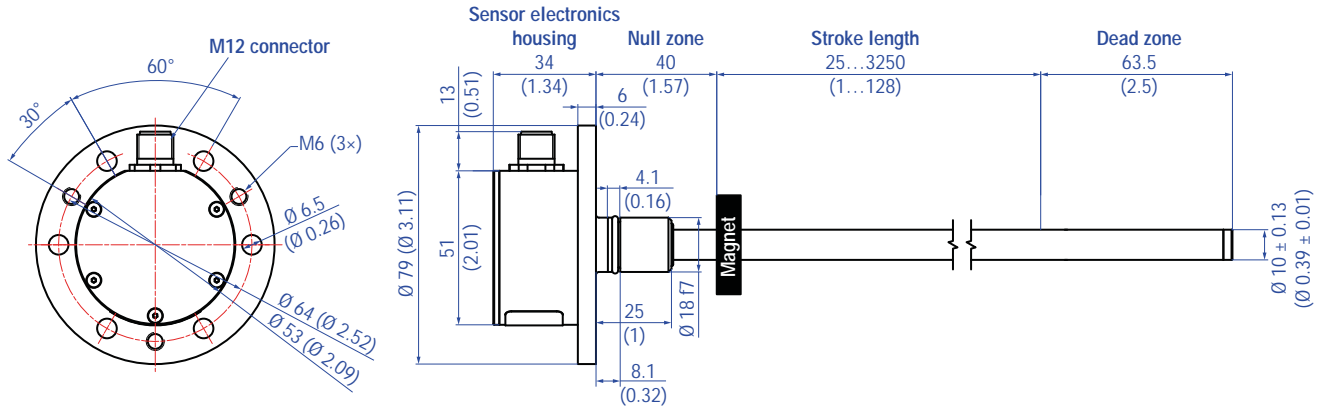

GB-K, example: With M16 connector

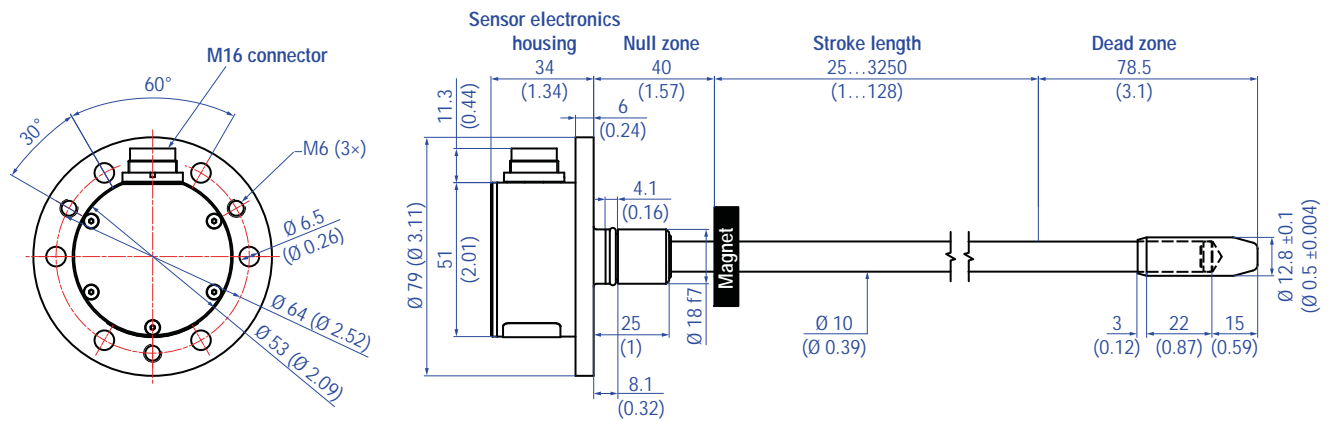

GB-J, example: With cable outlet

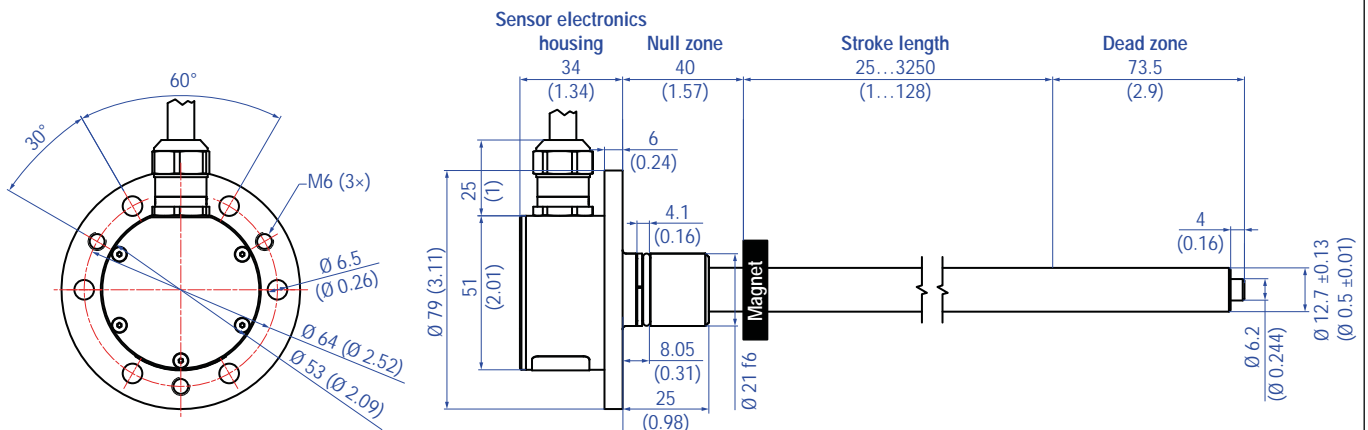

Controlling design dimensions are in millimeters and measurements in () are in inches

Fig. 3: Temposonics® GB-N / GB-S / GB-K / GB-J

Installation of GB with pressure fit flange

Mount the sensor via pressure fit flange through the bores in the sensor electronics housing with 6 machine screws M6×16 A2-70 (ISO 4762).

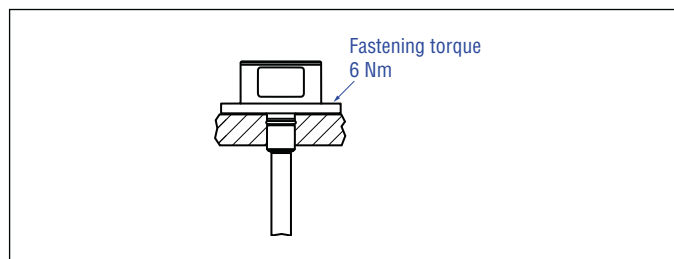

Fig. 4: Installation of GB with pressure fit flange »S« & »N«

Installation of a rod-style sensor in a hydraulic cylinder

The rod-style version has been developed for direct stroke measurement in a hydraulic cylinder. Mount the sensor through the bores in the sensor electronics housing with 6 machine screws M6×16 A2-70 (ISO 4762).

- Mounted on the face of the piston, the position magnet travels over the rod without touching it and indicates the exact position through the rod wall – independent of the hydraulic fluid.
- The pressure resistant sensor rod is installed into a bore in the piston rod.

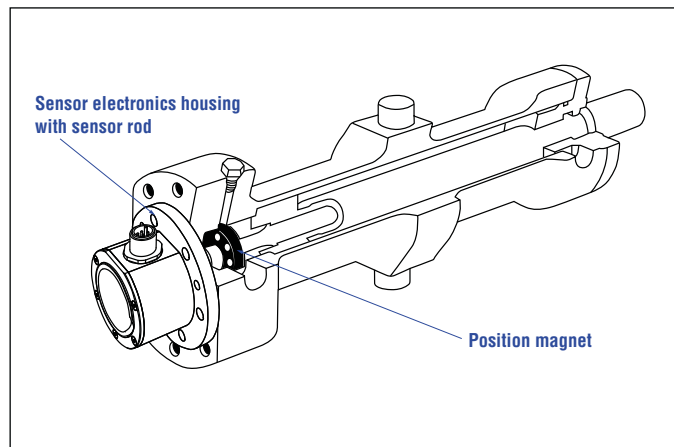

Fig. 5: Sensor in cylinder

Hydraulics sealing

Seal the flange contact surface via O-ring in the undercut as shown in Fig. 6.

For pressure fit flange Ø18 f7 (GB-K / GB-N / GB-S):

O-ring 15 × 2 mm (0.59 × 0.08 in.) (part no. 560 853)

For pressure fit flange Ø21 f6 (GB-J):

O-ring 17 × 2 mm (0.67 × 0.07 in.) (part no. 561 438)

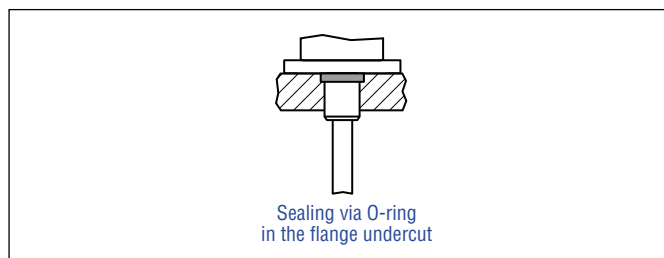
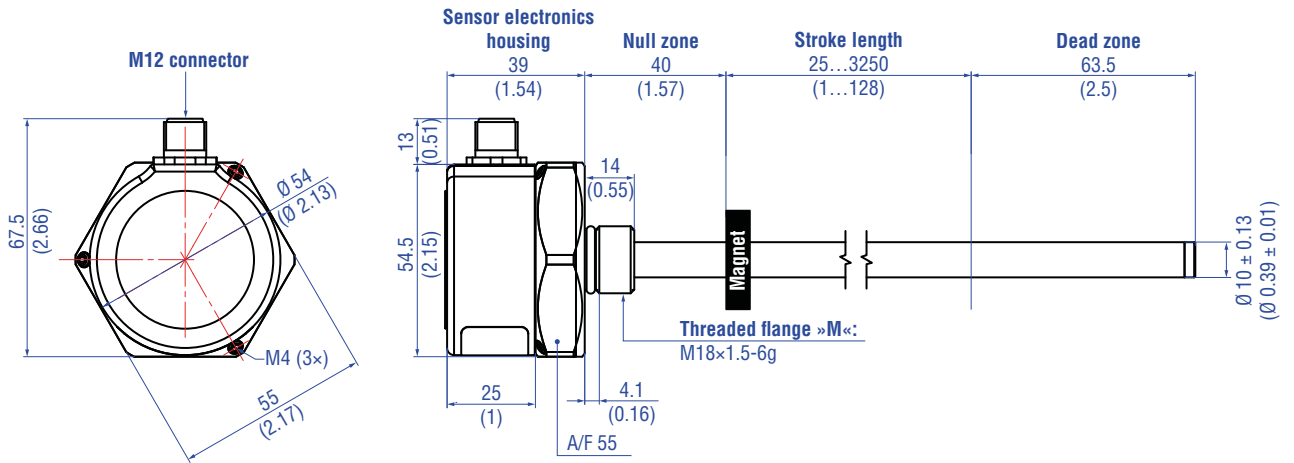

Fig. 6: Sealing

- Note the fastening torque of machine screws of 6 Nm.
- Seat the flange contact surface completely on the cylinder mounting surface.
- The cylinder manufacturer determines the pressure-resistant gasket (copper gasket, O-ring, etc.).
- The position magnet should not grind on the sensor rod.
- The piston rod drilling (GB-N / GB-S: $\geq \text{Ø } 13 \text{ mm}$ ($\geq \text{Ø } 0.52 \text{ in.}$), GB-J / GB-K: $\geq \text{Ø } 16 \text{ mm}$ ($\geq \text{Ø } 0.63 \text{ in.}$)) depends on the pressure and piston speed.
- Adhere to the information relating to operating pressure.
- Protect the sensor rod against wear.

4.3 Styles and installation of Temposonics® GB-M / GB-T / GB-B (rod sensor with threaded flange)

M12 connector (Example: With flat-faced flange)



M16 connector (Example: With raised-faced flange)

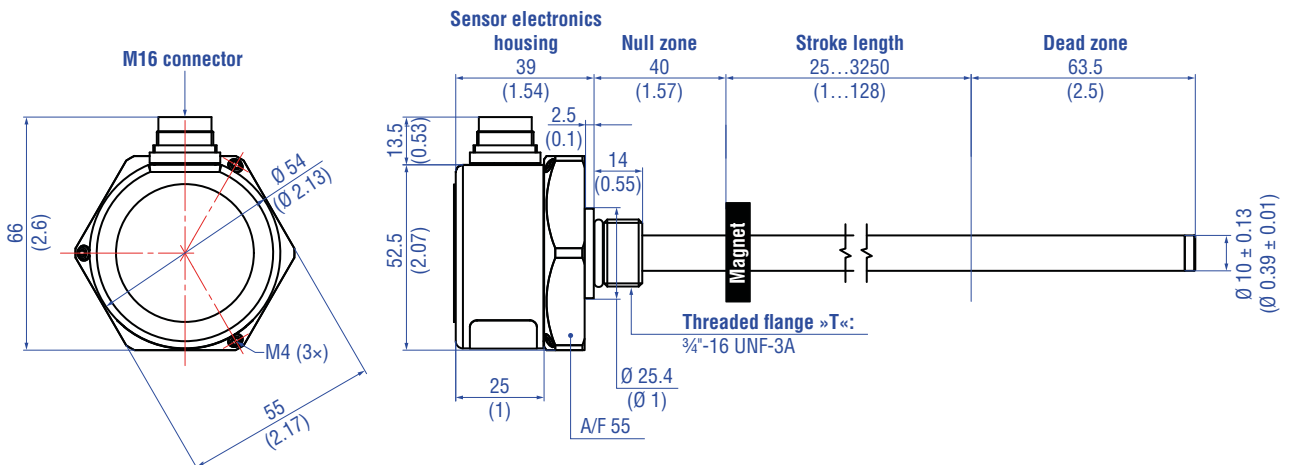

Cable outlet (Example: With flat-faced flange)

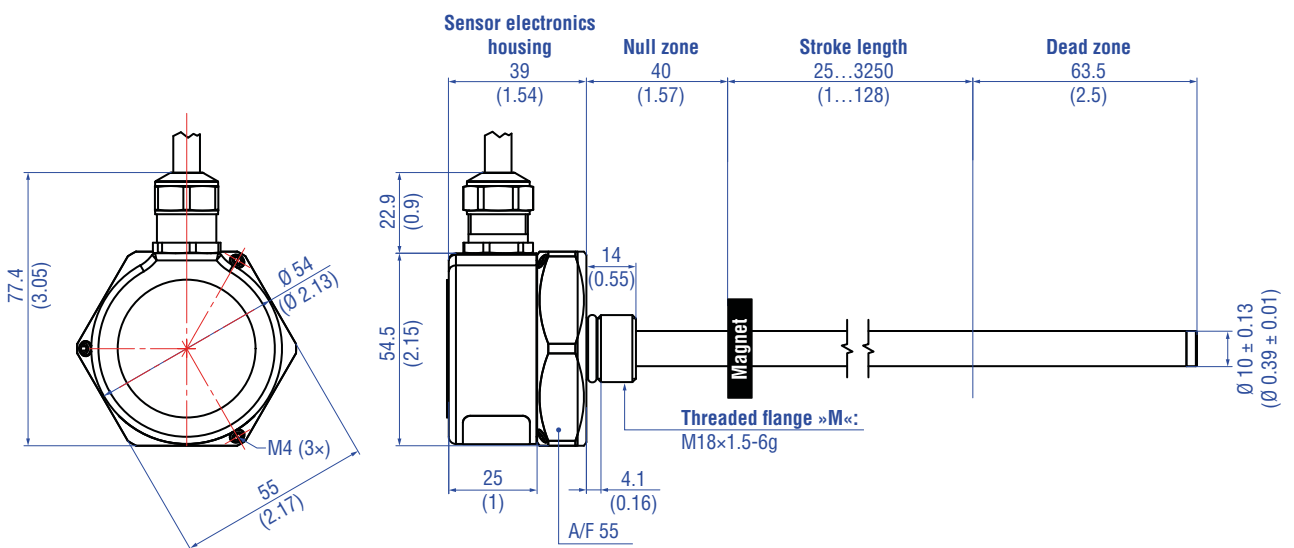

Controlling design dimensions are in millimeters and measurements in () are in inches

Fig. 7: Temposonics® GB-M / GB-T

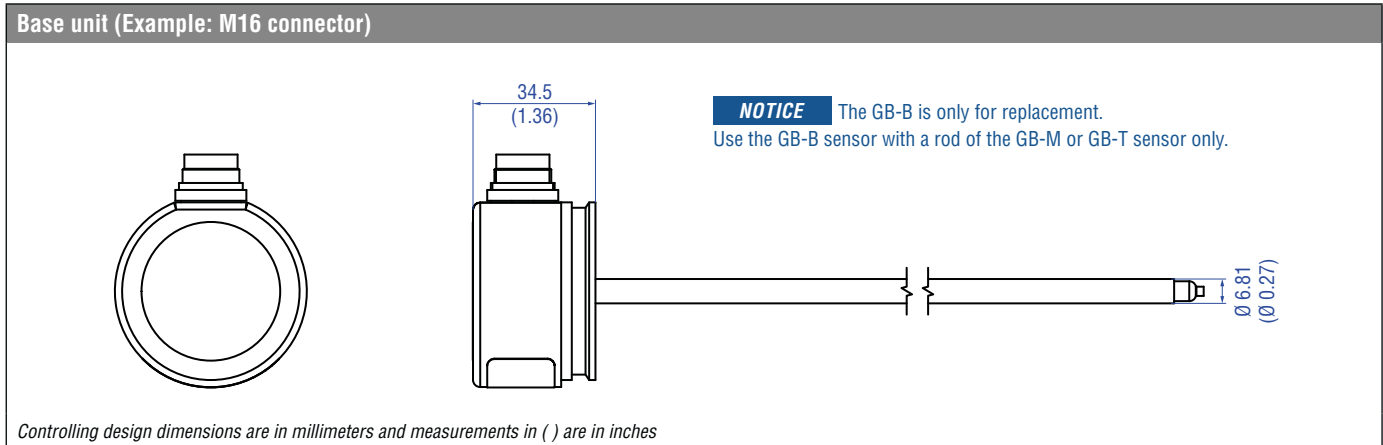

Fig. 8: Temposonics® GB-B

Installation of GB with threaded flange »M« & »T«

Fix the sensor rod via threaded flange M18×1.5-6g or ¾"-16 UNF-3A.

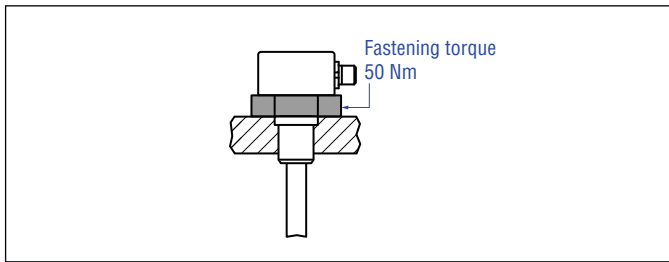

Fig. 9: Mounting example of threaded flange »M« & »T«

Installation of a rod-style sensor in a hydraulic cylinder

The rod-style version has been developed for direct stroke measurement in a hydraulic cylinder. Mount the sensor via threaded flange.

- Mounted on the face of the piston, the position magnet travels over the rod without touching it and indicates the exact position through the rod wall – independent of the hydraulic fluid.
- The pressure resistant sensor rod is installed into a bore in the piston rod.
- The base unit is mounted by means of only three screws. It is the only part that needs to be replaced if servicing is required, i.e. the hydraulic circuit remains closed. For more information see chapter "4.6 Replacement of base unit" on page 13.

NOTICE

The orientation of the sensor electronics housing respectively of the electrical connection of sensor models GB-M and GB-T can be changed after mounting. For more information see chapter "4.5 Change orientation of sensor electronics housing" on page 13.

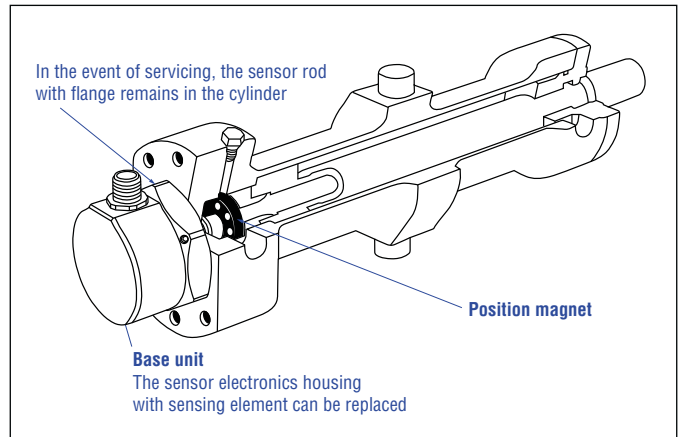

Fig. 10: Sensor in cylinder

Hydraulics sealing

There are two ways for sealing the flange contact surface (Fig. 11):

1. A sealing by using an O-ring (e.g. 22.4 × 2.65 mm (0.88 × 0.1 in.), 25.07 × 2.62 mm (0.99 × 0.1 in.)) in a cylinder end cap groove.
 2. A sealing by using an O-ring in the undercut.
- For threaded flange (¾"-16 UNF-3A) (GB-T):
O-ring 16.4 × 2.2 mm (0.65 × 0.09 in.) (part no. 560 315)
- For threaded flange (M18×1.5-6g) (GB-M):
O-ring 15.3 × 2.2 mm (0.60 × 0.09 in.) (part no. 401 133)

In the case of threaded flange M18×1.5-6g, a screw hole based on ISO 6149-1 (Fig. 12) must be provided. See ISO 6149-1 for further information.

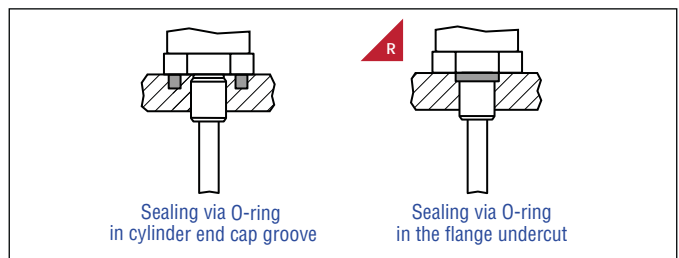

Fig. 11: Possibilities of sealing

MTS recommendation

- Note the fastening torque of 50 Nm.
- Seat the flange contact surface completely on the cylinder mounting surface.
- The cylinder manufacturer determines the pressure-resistant gasket (copper gasket, O-ring, etc.).
- The position magnet should not grind on the sensor rod.
- The piston rod drilling ($\geq \varnothing 13 \text{ mm}$ ($\geq \varnothing 0.52 \text{ in.}$)) depends on the pressure and piston speed.
- Adhere to the information relating to operating pressure.
- Protect the sensor rod against wear.

Notice for metric threaded flange

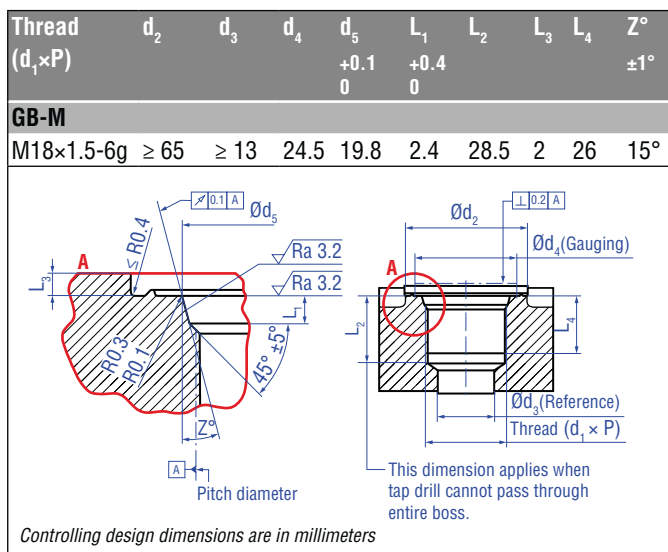

Fig. 12: Notice for threaded flange M18x1.5-6g based on DIN ISO 6149-1

4.4 Magnet installation

Typical use of magnets



Magnet	Benefits
Ring magnets 	<ul style="list-style-type: none"> • Rotationally symmetrical magnetic field
U-magnets 	<ul style="list-style-type: none"> • Height tolerances can be compensated

Fig. 13: Typical use of ring magnets and U-magnets

Mounting ring magnets and U-magnets

Install the magnet using non-magnetic material for mounting device, screws, spacers etc.. The magnet must not grind on the sensor rod. Alignment errors are compensated via the air gap.

- Permissible surface pressure: Max. 40 N/mm²
- Fastening torque for M4 screws: 1 Nm; use washer, if necessary
- Minimum distance between position magnet and any magnetic material has to be 15 mm (0.6 in.) (Fig. 15).
- If no other option exists and magnetic material is used, observe the specified dimensions (Fig. 15).

NOTICE

Mount ring magnets and U-magnets concentrically.
Do not exceed the maximum acceptable gap.

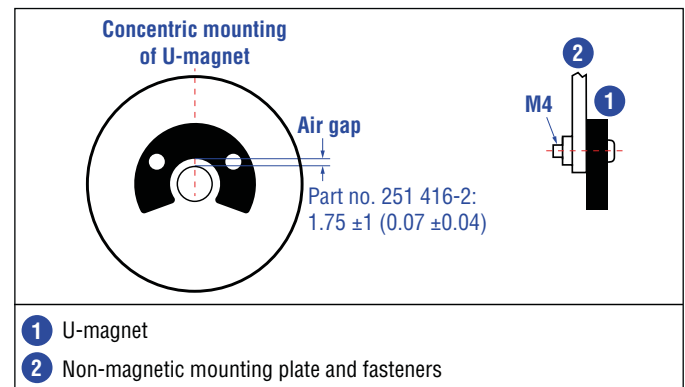

Fig. 14: Mounting of U-magnet, part no. 251 416-2

Magnet mounting with magnetic material

When using magnetic material the dimensions of Fig. 15 must be observed.

- A.** If the position magnet aligns with the drilled piston rod
- B.** If the position magnet is set further into the drilled piston rod, install another non-magnetic spacer (e.g. part no. 400 633) above the magnet.

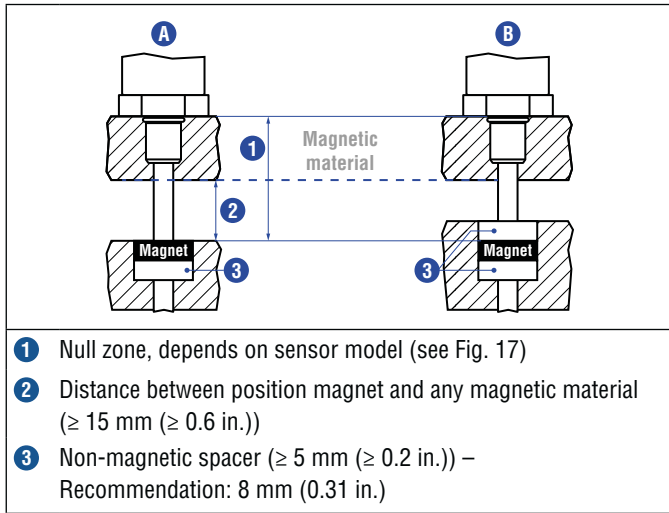

Fig. 15: Installation with magnetic material

Sensors with stroke lengths ≥ 1 meter (3.3 ft.)

Support horizontally installed sensors with a stroke length from 1 meter mechanically at the rod end. Without the use of a support, rod and position magnet may be damaged. A false measurement result is also possible. Longer rods require evenly distributed mechanical support over the entire length (e.g. part no. 561 481). Use an U-magnet (Fig. 16) for measurement.

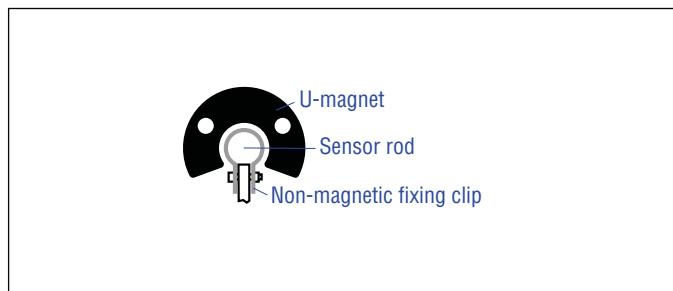

Fig. 16: Example of sensor support

Active measuring range

The technical data of each sensor is checked as well as documented and the active stroke length (useful electrical stroke) with its start and end position is adjusted during final inspection and testing (Fig. 17). To ensure that the entire measuring range can be used electrically, the position magnet must be mounted mechanically as follows:

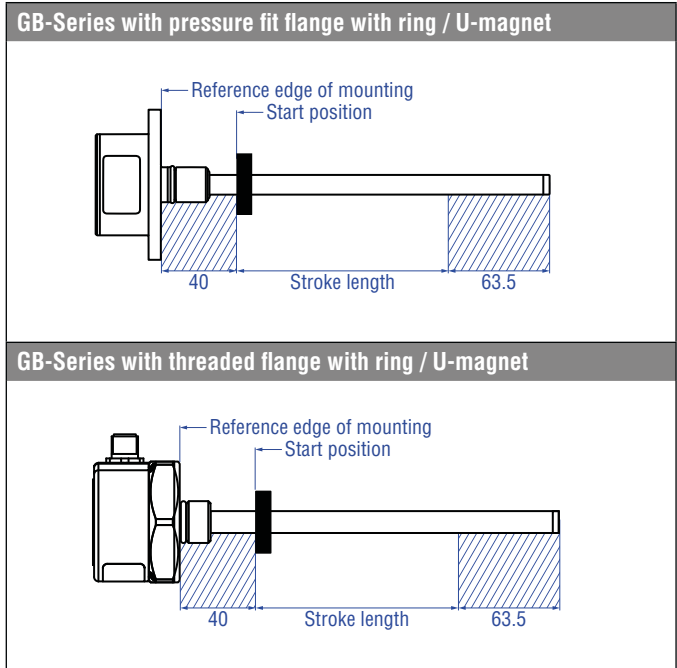

Fig. 17: Active measuring range

NOTICE

On all sensors, the areas left and right of the active stroke length are provided for null and dead zone. These zones should not be used for measurement, however the active stroke length can be exceeded.

4.5 Change orientation of sensor electronics housing

The orientation of the sensor electronics housing respectively of the electrical connection of sensor models GB-M and GB-T can be changed after mounting. Follow the instructions in Fig. 18.

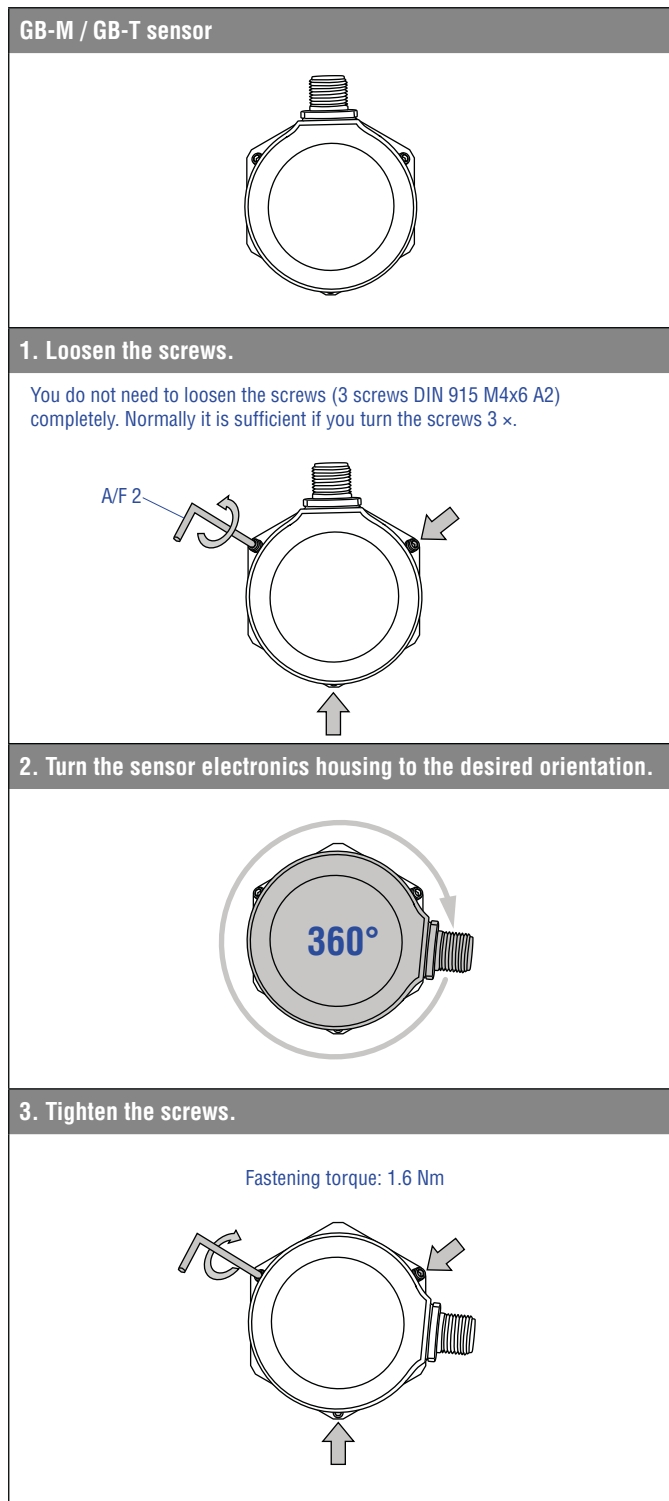

Fig. 18: Align sensor electronics housing respectively electrical connection of GB-M / GB-T

4.6 Replacement of base unit

The base unit of the sensor models GB-M and GB-T is replaceable as shown in Fig. 19. The sensor can be replaced without interrupting the hydraulic circuit.

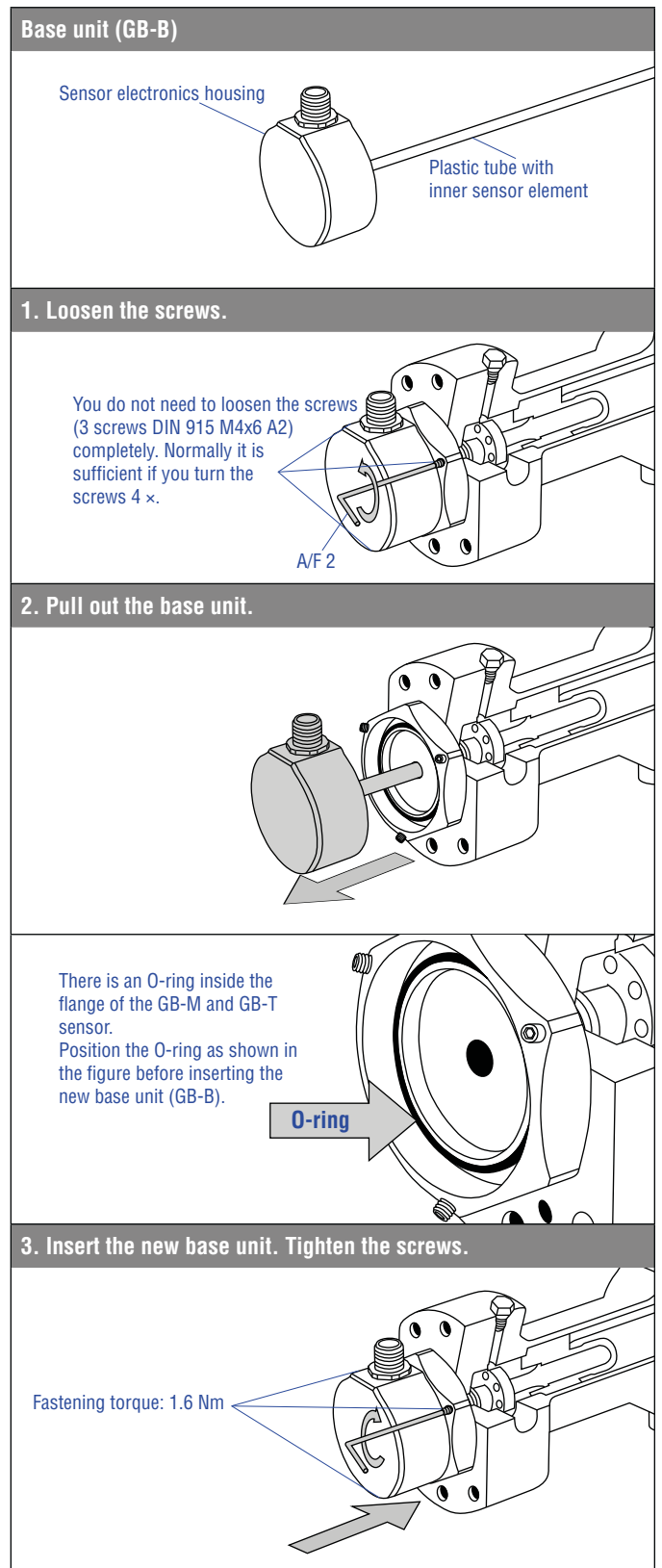

Fig. 19: Replacement of the base unit (GB-B)

4.7 Electrical connection

Placement of installation and cabling have decisive influence on the sensor's electromagnetic compatibility (EMC). Hence correct installation of this active electronic system and the EMC of the entire system must be ensured by using suitable metal connectors, shielded cables and grounding. Overvoltages or faulty connections can damage the sensor electronics despite protection against wrong polarity.

NOTICE

- Do not mount the sensors in the area of strong magnetic or electric noise fields.
- Never connect / disconnect the sensor when voltage is applied.

Instruction for connection

- Use low-resistance twisted pair and shielded cables. Connect the shield to ground externally via the controller equipment.
- Keep control and signal leads separate from power cables and sufficiently far away from motor cables, frequency inverters, valve lines, relays, etc..
- Use only metal connectors and connect the shielding to the connector housing.
- Keep the connection surface at both shielding ends as large as possible. Connect the cable clamps to function as a ground.
- Keep all non-shielded leads as short as possible.
- Keep the ground connections short and with a large cross section. Avoid ground loops.
- With potential differences between machine and electronics earth connections, no compensating currents are allowed to flow across the cable shielding.
Recommendation: Install potential compensating leads with large cross section, or use cables with separate double shielding, and connect only one end of the shield.
- Use only stabilized power supplies and make sure that the specified connecting values are met.

Grounding of rod sensors

Connect the sensor electronics housing to the machine ground via pressure fit flange respectively via threaded flange.

Connector wiring

Connect the sensor directly to the control system, indicator or other evaluating systems as follows:

D34 (for outputs: V0, A0, A1, A2, A3 in order code)			
Signal + power supply			
M12 male connector (A-coded)	Pin	Voltage	Current
 <p>View on sensor</p>	1	+24 VDC (-15 / +20 %)	+24 VDC (-15 / +20 %)
	2	0...10 VDC	4(0)...20 mA or 20... 4(0) mA
	3	DC Ground (0 V)	DC Ground (0 V)
	4	10...0 VDC	Not connected *
	5	DC Ground	DC Ground

* Connection necessary for programming with hand or cabinet programmer

Fig. 20: Connector wiring D34 (M12) for outputs V0, A0, A1, A2 and A3

D34 (for output: A4 in order code)		
Signal + power supply		
M12 male connector (A-coded)	Pin	Current
 <p>View on sensor</p>	1	+24 VDC (-15 / +20 %)
	2	4...20 mA *
	3	DC Ground (0 V)
	4	20...4 mA
	5	DC Ground

* Connect the first output (4...20 mA) at low-resistance, if you only use the second output (20...4 mA)

Fig. 21: Connector wiring D34 (M12) for output A4

D60 (for outputs: V0, A0, A1, A2, A3 in order code)			
Signal + power supply			
M16 male connector	Pin	Voltage	Current
 <p>View on sensor</p>	1	0...10 VDC	4(0)...20 mA or 20... 4(0) mA
	2	DC Ground	DC Ground
	3	10...0 VDC	Not connected *
	4	DC Ground	DC Ground
	5	+24 VDC (-15 / +20 %)	+24 VDC (-15 / +20 %)
	6	DC Ground (0 V)	DC Ground (0 V)

* Connection necessary for programming with hand or cabinet programmer

Fig. 22: Connector wiring D60 (M16) for outputs V0, A0, A1, A2 and A3

D60 (for output: A4 in order code)		
Signal + power supply		
M16 male connector	Pin	Current
 <p>View on sensor</p>	1	4...20 mA *
	2	DC Ground
	3	20...4 mA
	4	DC Ground
	5	+24 VDC (-15 / +20 %)
	6	DC Ground (0 V)

* Connect the first output (4...20 mA) at low-resistance, if you only use the second output (20...4 mA)

Fig. 23: Connector wiring D60 (M16) for output A4

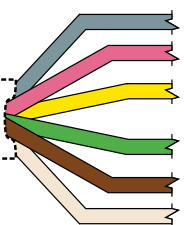
HXX / TXX / VXX (for outputs: V0, A0, A1, A2, A3 in order code)			
Signal + power supply			
Cable	Color	Voltage	Current
	GY	0...10 VDC	4(0)...20 mA or 20... 4(0) mA
	PK	DC Ground	DC Ground
	YE	10...0 VDC	Not connected *
	GN	DC Ground	DC Ground
	BN	+24 VDC (-15 / +20 %)	+24 VDC (-15 / +20 %)
	WH	DC Ground (0 V)	DC Ground (0 V)

* Connection necessary for programming with hand or cabinet programmer

Fig. 24: Connector wiring cable outlet for outputs V0, A0, A1, A2 and A3

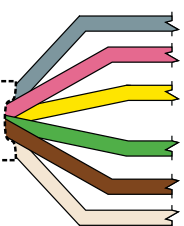
HXX / TXX / VXX (for output: A4 in order code)		
Signal + power supply		
Cable	Color	Current
	GY	4...20 mA *
	PK	DC Ground
	YE	20...4 mA
	GN	DC Ground
	BN	+24 VDC (-15 / +20 %)
	WH	DC Ground (0 V)

* Connect the first output (4...20 mA) at low-resistance, if you only use the second output (20...4 mA)

Fig. 25: Connector wiring cable outlet for output A4

NOTICE
DANGER OF SHORT-CIRCUIT!

Insulate the conductors of the second output (yellow, green), if you only use the first output. We recommend providing terminals for the second output in the control cabinet, since the leads are required for sensor programming.

4.8 Frequently ordered accessories – Additional options available in our [Accessories Guide](#) 551 444

Position magnets

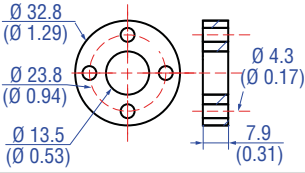
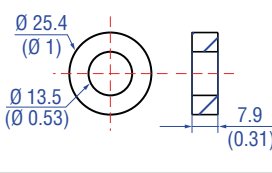
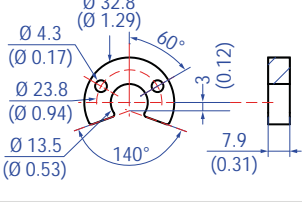
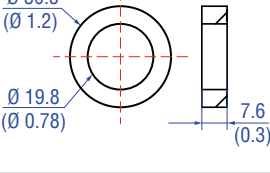
			
<p>Ring magnet OD33 Part no. 201 542-2</p> <p>Material: PA ferrite GF20 Weight: Approx. 14 g Surface pressure: Max. 40 N/mm² Fastening torque for M4 screws: 1 Nm Operating temperature: -40...+105 °C (-40...+221 °F)</p>	<p>Ring magnet OD25.4 Part no. 400 533</p> <p>Material: PA ferrite Weight: Approx. 10 g Surface pressure: Max. 40 N/mm² Operating temperature: -40...+105 °C (-40...+221 °F)</p>	<p>U-magnet OD33 Part no. 251 416-2</p> <p>Material: PA ferrite GF20 Weight: Approx. 11 g Surface pressure: Max. 40 N/mm² Fastening torque for M4 screws: 1 Nm Operating temperature: -40...+105 °C (-40...+221 °F)</p>	<p>Ring magnet Part no. 402 316</p> <p>Material: PA ferrite coated Weight: Approx. 13 g Surface pressure: Max. 20 N/mm² Operating temperature: -40...+100 °C (-40...+212 °F)</p>

Position magnet

O-rings

Back-up ring

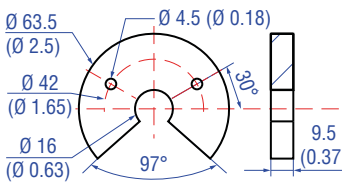
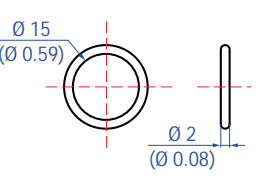
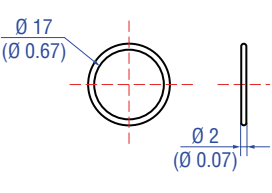
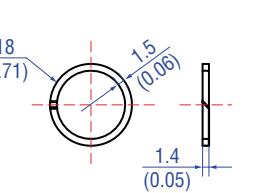
			
<p>U-magnet OD63.5 Part no. 201 553</p> <p>Material: PA 66-GF30, magnets compound-filled Weight: Approx. 26 g Surface pressure: 20 N/mm² Fastening torque for M4 screws: 1 Nm Operating temperature: -40...+75 °C (-40...+167 °F)</p>	<p>O-ring for pressure fit flange Ø 18 mm Part no. 560 853</p> <p>Material: Fluoroelastomer Durometer: 75 Shore A</p>	<p>O-ring for pressure fit flange Ø 21 mm Part no. 561 438</p> <p>Material: FKM Durometer: 80 Shore A Operating temperature: -18...+200 °C (-0.4...+392 °F)</p>	<p>Back-up ring for pressure fit flange Ø 18 mm Part no. 561 115</p> <p>Material: PTFE + 60 % bronze</p>

Back-up ring

Optional installation hardware

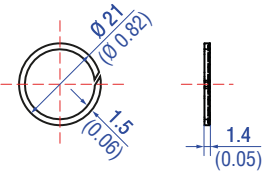
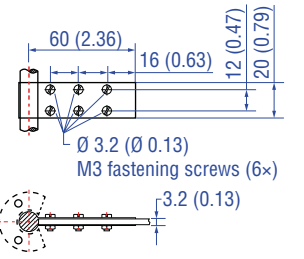
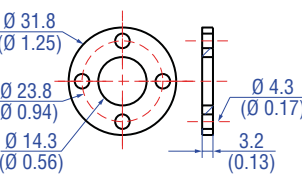

Magnet spacer

		
<p>Back-up ring for pressure fit flange Ø 21 mm Part no. 561 439</p> <p>Material: PTFE</p>	<p>Fixing clip for rod with Ø 10 mm Part no. 561 481</p> <p>Application: Used to secure sensor rods (Ø 10 mm (Ø 0.39 in.)) when using an U-magnet or block magnet Material: Brass, non-magnetic</p>	<p>Magnet spacer Part no. 400 633</p> <p>Material: Aluminum Weight: Approx. 5 g Surface pressure: Max. 20 N/mm² Fastening torque for M4 screws: 1 Nm</p>

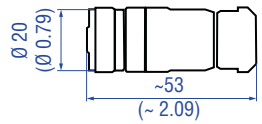
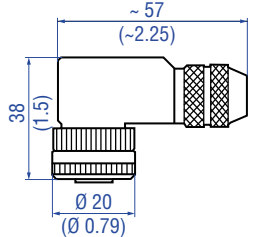
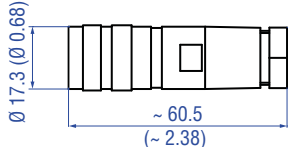
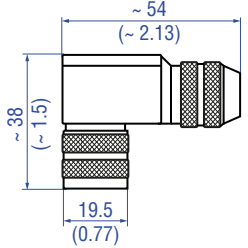
Cable connectors⁵

			
<p>M12 A-coded female connector (5 pin), straight Part no. 370 677</p>	<p>M12 A-coded female connector (5 pin), angled Part no. 370 678</p>	<p>M16 female connector (6 pin), straight Part no. 370 423</p>	<p>M16 female connector (6 pin), angled Part no. 370 460</p>
<p>Material: GD-Zn, Ni Termination: Screw Contact insert: CuZn Cable Ø: 4...8 mm (0.16...0.31 in.) Wire: 1.5 mm² Operating temperature: -30...+85 °C (-22...+185 °F) Ingress protection: IP67 (correctly fitted) Fastening torque: 0.6 Nm</p>	<p>Material: GD-Zn, Ni Termination: Screw; max. 0.75 mm² Contact insert: CuZn Cable Ø: 5...8 mm (0.2...0.31 in.) Wire: 0.75 mm² (18 AWG) Operating temperature: -25...+85 °C (-13...+185 °F) Ingress protection: IP67 (correctly fitted) Fastening torque: 0.4 Nm</p>	<p>Material: Zinc nickel plated Termination: Solder Cable Ø: 6...8 mm (0.24...0.31 in.) Operating temperature: -40...+100 °C (-40...+212 °F) Ingress protection: IP65 / IP67 (correctly fitted) Fastening torque: 0.6 Nm</p>	<p>Material: Zinc nickel plated Termination: Solder Cable Ø: 6...8 mm (0.24...0.31 in.) Wire: 0.75 mm² (20 AWG) Operating temperature: -40...+95 °C (-40...+203 °F) Ingress protection: IP67 (correctly fitted) Fastening torque: 0.6 Nm</p>

Cables

		
<p>PUR cable Part no. 530 052</p> <p>Material: PUR jacket; orange Features: Twisted pair, shielded, highly flexible Cable Ø: 6.4 mm (0.25 in.) Cross section: 3 × 2 × 0.25 mm² Bending radius: 5 × Ø (fixed insulation) Operating temperature: -30...+80 °C (-22...+176 °F)</p>	<p>Teflon® cable Part no. 530 112</p> <p>Material: Teflon® jacket; black Features: Twisted pair, shielded, flexible Cable Ø: 7.6 mm (0.3 in.) Cross section: 4 × 2 × 0.25 mm² Bending radius: 8 – 10 × Ø (fixed installation) Operating temperature: -100...+180 °C (-148...+356 °F)</p>	<p>Silicone cable Part no. 530 113</p> <p>Material: Silicone jacket; red Features: Twisted pair, shielded, highly flexible Cable Ø: 7.2 mm (0.28 in.) Cross section: 3 × 2 × 0.25 mm² Bending radius: 5 × Ø (fixed installation) Operating temperature: -50...+180 °C (-58...+356 °F)</p>

Programming tool

<p>Programming kit Part no. 254 555</p> <p>Kit includes:</p> <ul style="list-style-type: none"> 1 × interface converter box, 1 × power supply 1 × cable (60 cm) with M12 female connector (5 pin), straight – D-sub female connector (9 pin), straight 1 × cable (60 cm) with M16 female connector (6 pin), straight – D-sub female connector (9 pin), straight 1 × cable (60 cm) with 3 × terminal clamp – D-sub female connector (9 pin), straight 1 × USB cable <p>Software is available at: www.mtssensors.com</p>

Programming tools

	
<p>Hand programmer for analog output Part no. 253 124</p> <p>Easy teach-in-setups of stroke length and direction on desired zero / span positions. For sensors with 1 magnet.</p>	<p>Cabinet programmer for analog output Part no. 253 408</p> <p>Features snap-in mounting on standard DIN rail (35 mm). This programmer can be permanently mounted in a control cabinet and includes a program / run switch. For sensors with 1 magnet.</p>

5. Operation

5.1 Getting started

The sensor is factory-set to its order sizes and adjusted, i.e. the required output signal corresponds exactly to the selected stroke length.

Example: Output 4...20 mA = 0...100 % stroke length

NOTICE If necessary, the analog sensors can be re-adjusted using the service tools described below.

NOTICE

Observe during commissioning

1. Before initial switch-on, check carefully if the sensor has been connected correctly.
2. Position the magnet in the measuring range of the sensor during first commissioning and after replacement of the magnet.
3. Ensure that the sensor control system cannot react in an uncontrolled way when switching on.
4. Ensure that the sensor is ready and in operation mode after switching on.
5. Check the pre-set span start and end values of the measuring range (Fig. 17) and correct them via the customer's control system or via the MTS Sensors service tools, if necessary.
The operation of the service tools is described in detail on the following pages.

This chapter describes “programming and configuration” of the GB analog sensor via cable connection.
“Programming and configuration” via Bluetooth® connection are explained in document [551595](#).

MTS Sensors programming tools

Temposonics® sensors can be adapted to modified measurement tasks very easily via the connecting leads – without opening the sensor. For this, various MTS Sensors control units from the list of accessories (see page 17) are available.

5.2 Programming and configuration

Analog interface

The analog sensor can be directly connected to a controller. Its electronics generates a position signal output proportional to the start and end of the active measuring range.

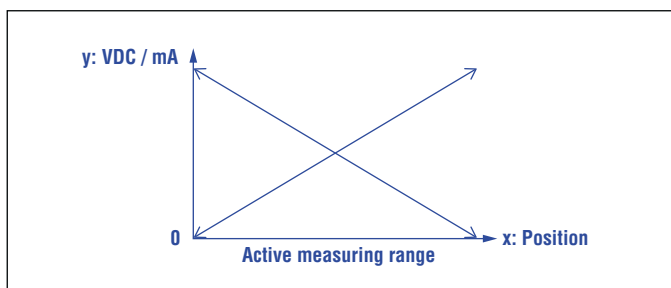

Fig. 26: Analog interface

5.2.1 Analog hand programmer, part no. 253 124

Connect the hand programmer directly to the sensor. It is possible to change the start and end positions as well as the measuring direction via simple teach in process, see also “5.2.4 Setting examples for programming tools” on page 23. After that, the changed parameters are stored in the sensor. Move the position magnet to the desired start or end position and push the corresponding “0 %” or “100 %” button on the hand programmer. The minimum distance between the new setpoints is 25 mm (1 in.). The individual steps are explained in the following section.

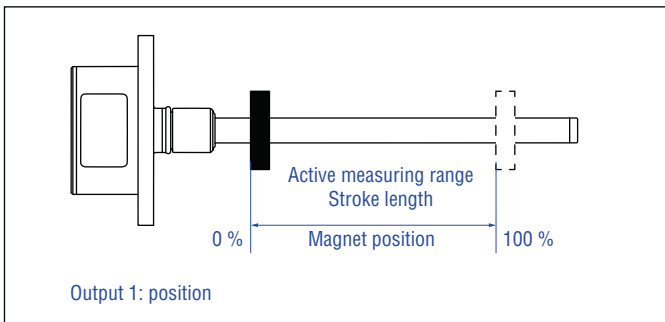

Fig. 27: Active measuring range (example of GB-S / GB-N)

- Step 1: Connect hand programmer
- Step 2: Adjust measuring range

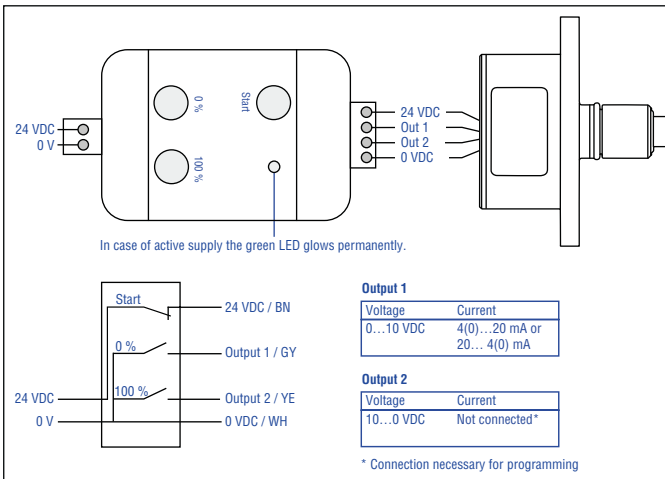

Fig. 28: Connect hand programmer (example of GB-S / GB-N)
(see Fig. 20, Fig. 21 on page 14)

Connect the hand programmer to the power supply and to the sensor according to Fig. 28.

NOTICE

You can only adapt output 1 via hand programmer. In order to change the settings of output 1 you have to connect both outputs (output 1 and output 2).

- Step 1: Connect hand programmer
- Step 2: Adjust measuring range

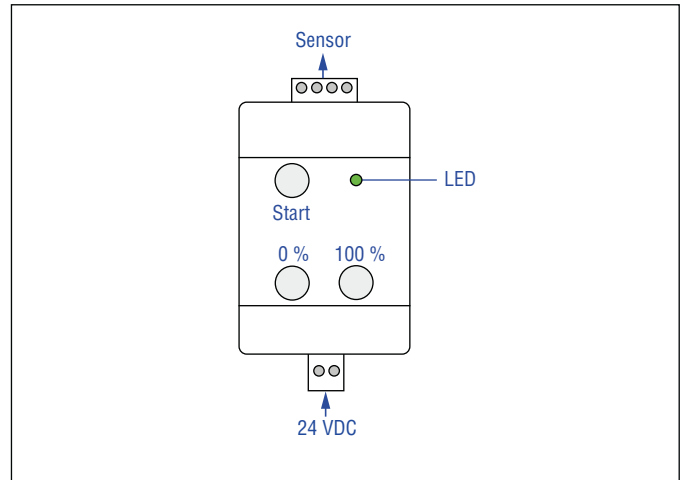

Fig. 29: Adjust measuring range

1. Activate programming mode:
 - Press “Start” button and “100 %” button simultaneously
 - Release “Start” button first, wait 1 second and release “100 %” button
2. Set start position (0 % output) (Fig. 30):
 - Set the position magnet on start position
 - Press and release the “0 %” button
3. Set end position (100 % output) (Fig. 30):
 - Set the position magnet on end position
 - Press and release the “100 %” button

Start position (0 % output)	End position (100 % output)
0 VDC	10 VDC
0 mA	20 mA
4 mA	20 mA
20 mA	0 mA
20 mA	4 mA

Fig. 30: Determine start and end position

4. Back to normal function (operation mode):
 - Press “Start” button
 - Connect the sensor to control unit

5.2.2 Analog cabinet programmer, part no. 253 408

Install the built-in programming unit firmly in the control cabinet. It is possible to change the start and end positions as well as the measuring direction via simple teach in process, see also “5.2.4 Setting examples for programming tools” on page 23. After that, the changed parameters are stored in the sensor. Move the position magnet to the desired start or end position and push the corresponding “0 %” or “100 %” button on the hand programmer. The minimum distance between the new setpoints is 25 mm (1 in.). The individual steps are explained in the following section.

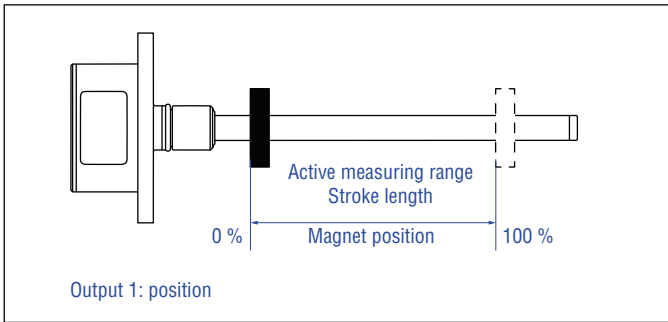

Fig. 31: Active measuring range (example of GB-S / GB-N)

- Step 1: Install cabinet programmer
- Step 2: Connect cabinet programmer
- Step 3: Adjust measuring range

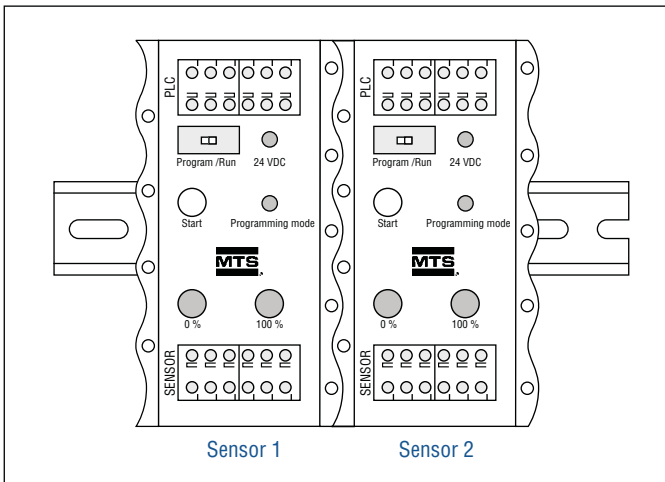

Fig. 32: Dimensions: 10 × 55 × 31 mm (0.39 × 2.17 × 1.22 in.); material: Aluminum, side caps PA 6.6 FR; connection type: Spring terminals, max. 1,5 mm²; ingress protection: IP20

The cabinet programmer is designed for mounting on standard 35 mm (1.38 in.) rails according to DIN EN 60715 / 50022. Install the cabinet programmer between sensor and controller e.g. in a control cabinet. Using the cabinet programmer the sensor can be easily re-programmed as needed with no additional tools.

- Step 1: Install cabinet programmer
- Step 2: Connect cabinet programmer
- Step 3: Adjust measuring range

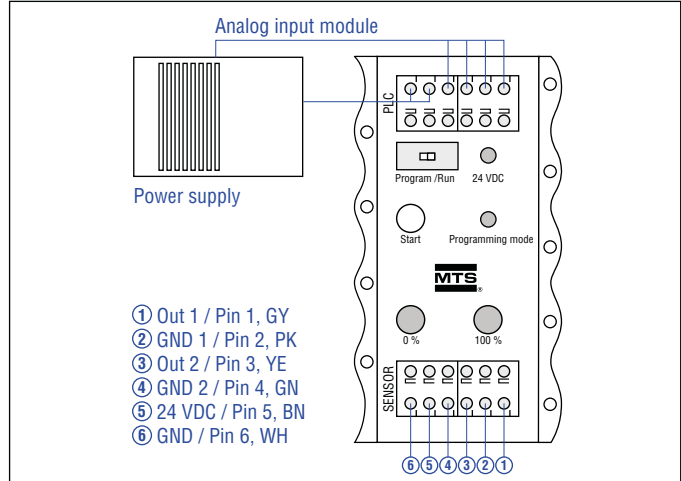

Fig. 33: Connect cabinet programmer (see connector wiring Fig. 20, Fig. 21 on page 14)

Connect the cabinet programmer to the controller, to the power supply and to the sensor according to Fig. 33.

- Step 1: Install cabinet programmer
- Step 2: Connect cabinet programmer
- Step 3: Adjust measuring range

1. Activate programming mode:
 - Slide switch to “Program”
 - Press “Start” button and “100 %” button simultaneously
 - Release “Start” button first, wait 1 second and release “100 %” button
 - Green “Programming mode” LED on cabinet programmer flashes (programming mode reached)
2. Set start position (0 % output) (Fig. 34):
 - Set the position magnet to start position
 - Press and release the “0 %” button
3. Set end position (100 % output) (Fig. 34):
 - Set the position magnet to end position
 - Press and release the “100 %” button

Start position (0 % output)	End position (100 % output)
0 VDC	10 VDC
0 mA	20 mA
4 mA	20 mA
20 mA	0 mA
20 mA	4 mA

Fig. 34: Determine start and end position

4. Back to normal function (operation mode):
 - Press and release the “Start” button
 - LED “Programming mode” stops flashing
 - Slide switch to “Run”
 - Green LED “24 VDC” shows normal function

5.2.3 Programming kit, part no. 254 555

The PC programmer is a hardware converter between sensor and serial PC interface. It can be used for adjusting sensor parameters via computer and the MTS Sensors programming software, see also “5.2.4 Setting examples for programming tools” on page 23. The software for reading and adjusting the sensors requires a Windows computer with a free USB port. You can adjust the following parameters:

- Start / end position (min. 25 mm (1 in.) between new setpoints)
- Output signal with errors (e.g. no position magnet)

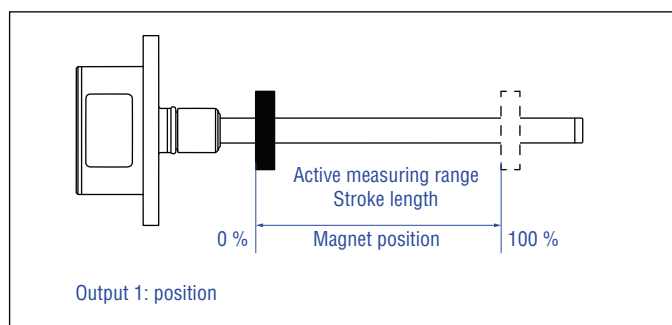

Fig. 36: Active measuring range (example of GB-S / GB-N)

- Step 1: Connect PC programmer
- Step 2: Install software**
- Step 3: Start program

Download the current software version from www.mtssensors.com. Copy the program MTSAnalogConfigurator.exe to your computer and start the program. The program now displays a list of available COMs. A free COM port is selected. The COM port, which was chosen, is displayed in the Device Manager. If a connection fails, it could be a missing driver. In this case, download and install the USB serial converter driver from www.mtssensors.com.

- Step 1: Connect PC programmer
- Step 2: Install software
- Step 3: Start program**

After starting the program, the user interface of the connected sensor with its adjustable parameters will open (Fig. 37).

- Step 1: Connect PC programmer**
- Step 2: Install software
- Step 3: Start program

- Connect the PC programmer with the sensor via the corresponding adapter cable
- Connect the PC programmer to a USB port of the computer
- Connect the power supply via connector
The outer contact of the connector is 0 V (ground), the inner contact is 24 VDC

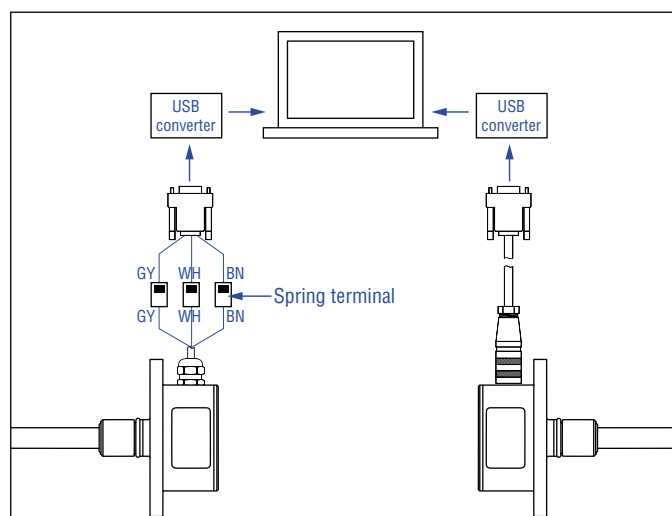

Fig. 35: Connect PC programmer (example of GB-S / GB-N)
(for sensors with cable outlet on the left, for sensors with connector outlet on the right)

NOTICE

Never connect / disconnect the sensor when voltage is applied.

GB Analog software user interface

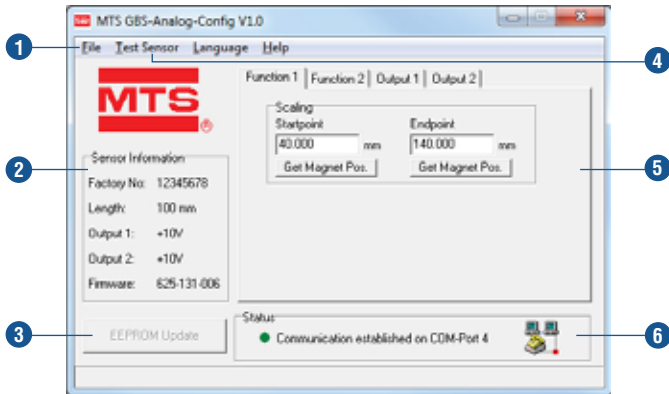

Fig. 37: Example of user interface

- 1 In the **File** menu the sensor configuration can be saved on hard disk, printed out or loaded into the sensor⁶. Moreover, this menu permits returning to the factory setting (Fig. 37).
- 2 **Sensor Information** contains the invariable sensor parameters, which were read in automatically when connecting the sensor. (Fig. 37).
- 3 Any changes which were made are shown with dark background. By clicking on **EEPROM Update** the altered parameters are stored in the sensor permanently. Subsequently, the stored values are displayed again with a white background (Fig. 37).
- 4 Menu **Test Sensor** provides a data display (Fig. 40), which shows the absolute position of the position magnet. Compared with the sensor measuring rate, the serial data transmission between sensor and PC is relatively slow, i.e. not every measured value can be displayed. For this reason, only every 50th measurement value appears in the diagram.
- 5 The control tabs of the main display section permit allocation of functions to the sensor outputs. The measuring range of the functions will be determined in **Scaling** (Fig. 37).
- 6 **Status** indicates that the sensor is connected successfully (Fig. 37).

Dialog field with tabs

- 7 Determine the measuring range with **Startpoint** and **Endpoint** via tab **Function 1** (Fig. 38).
- 8 The current magnet position can be stored via buttons **Get Magnet Pos.**. The measuring direction changes, when the value of the **startpoint** is higher than the value of the **endpoint**. Independent of the measuring direction, the minimum measuring distance is 25 mm (Fig. 38).
- 9 The field **Output Minimum** indicates the current or voltage value which should be output at the startpoint of the selected function. The output value pertaining to the endpoint must be specified in field **Output Maximum** (Fig. 39).

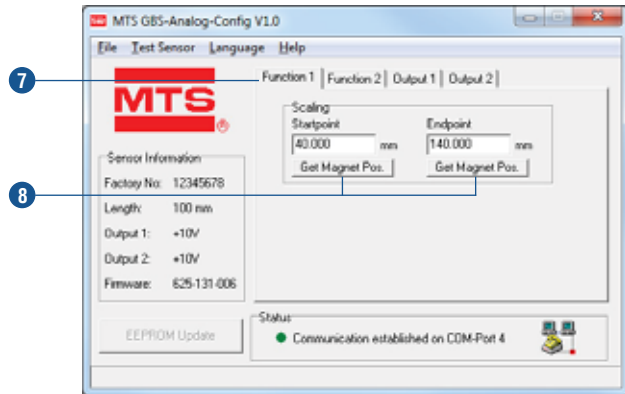

Fig. 38: Dialog field with tabs

- 10 On tabs **Function 2**, **Output 2**, the second analog output can be set (Fig. 39).
- 11 On tab **Output 1** the corresponding analog output signals can be allocated (Fig. 39).
- 12 Unless a position magnet is missing or if it is in the sensor's dead zone, i.e. out of measuring range, **Global Error** is output. The error value can be adjusted within **-0.7...20.3 mA** or **-0.4...10.4 VDC** (Fig. 39).

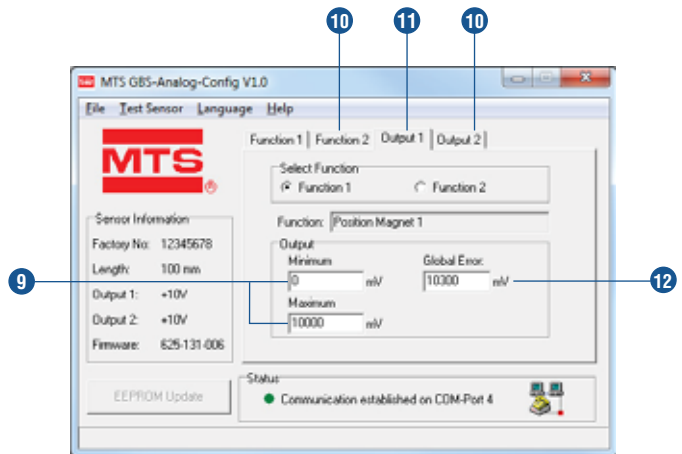

Fig. 39: Example of tab controls

6/ Only sensor configurations with the same serial number are permissible

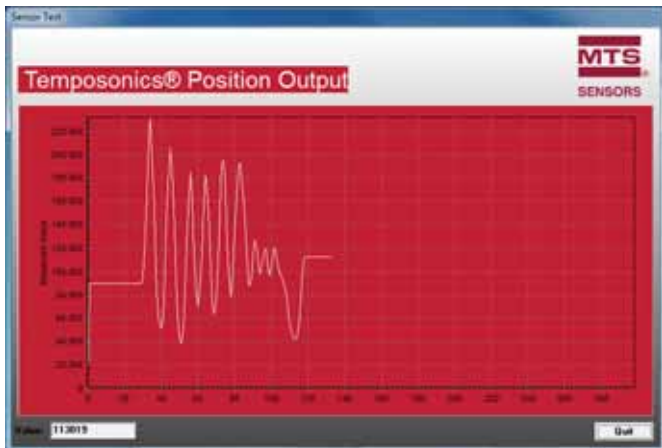

Fig. 40: Data display

5.2.4 Setting examples for programming tools

The sensor's measuring range can be repositioned using the tools described above at any time.

NOTICE

Independent of the measuring direction, the location of the setpoints in the factory settings is always: SP1 (set point 1) at sensor electronics housing and SP2 (set point 2) at rod end. (Fig. 41).

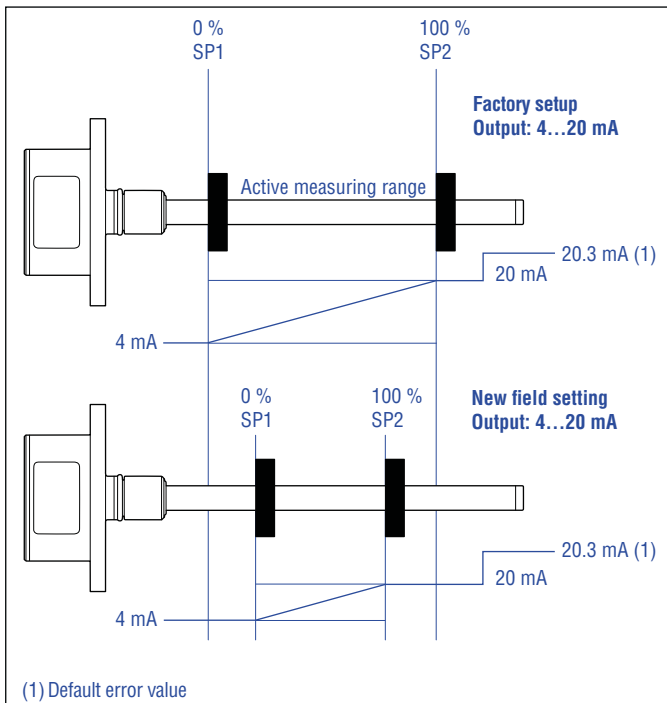

Fig. 41: Adjust start and end position (example of GB-S / GB-N)

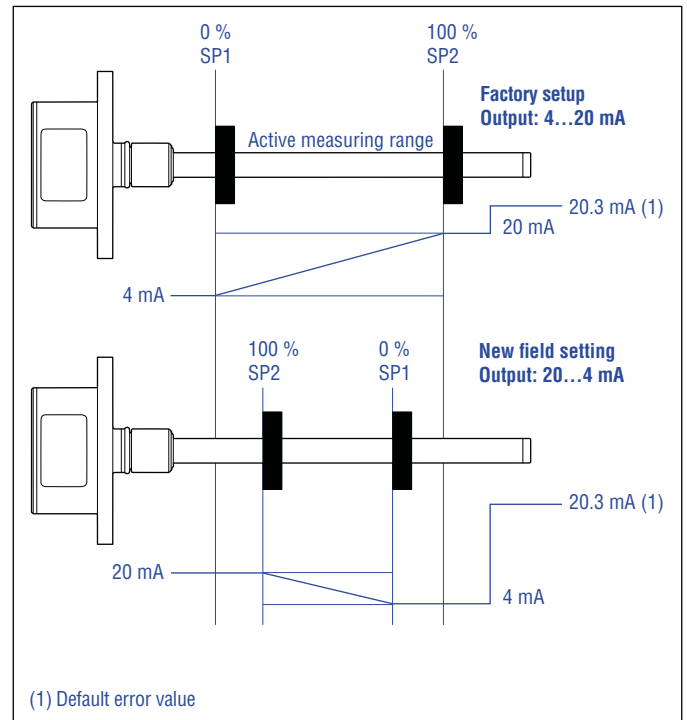

Fig. 42: Start and end position, adjustment / reversal of measuring direction (example of GB-S / GB-N)

6. Maintenance and troubleshooting

6.1 Error conditions, troubleshooting

Error condition	Status
Magnet error	Default error value at output: Voltage output: 10.35 V Current output: 20.3 mA Adapted error value at output: -0.7...20.3 mA or -0.4...10.4 VDC (see 12 on page 22)

6.2 Maintenance

The sensor is maintenance-free.

6.3 Repair

Repairs of the sensor may only be performed by MTS Sensors or an explicitly authorized body.

6.4 List of spare parts

No spare parts are available for this sensor.

6.5 Transport and storage

The conditions of transport and storage of the sensor match the operating conditions mentioned in this document.

7. Removal from service / dismantling

The product contains electronic components and must be disposed of in accordance with the local regulations.

8. Technical data

8.1 Technical data GB-J / GB-K / GB-N / GB-S

Output

Voltage	0...10 VDC and 10...0 VDC (minimum load controller: > 5 kΩ)
Current	4(0)...20 mA or 20...4(0) mA (minimum / maximum load: 0 / 500 Ω)
Programming	Programming of set points using optional accessories
Measured value	Position

Measurement parameters

Resolution	16 bit (minimum 1 μm depending on stroke length) ⁷			
Cycle time	Cycle time	0.5 ms	1.0 ms	2.0 ms
	Stroke length	≤ 1200 mm	≤ 2400 mm	> 2400 mm
Linearity ⁸	≤ ±0.02 % F.S. (minimum ±60 μm) typical			
Repeatability	≤ ±0.005 % F.S. (minimum ±20 μm) typical			

Operating conditions

Operating temperature	-40...+90 °C (-40...+194 °F); option: -40...+100 °C (-40...+212 °F)
Ingress protection	IP67 (correctly fitted); IP68 (for cable outlet)
Shock test	100 g (single shock), IEC standard 60068-2-27
Vibration test	15 g / 10...2000 Hz, IEC standard 60068-2-6 (excluding resonant frequencies)
EMC test	Electromagnetic emission according to EN 61000-6-4 Electromagnetic immunity according to EN 61000-6-2 The sensor meets the requirements of the EU directives and is marked with CE
Operating pressure	350 bar (5,076 psi), 700 bar (10,153 psi) peak (at 10 × 1 min), GB-J: 800 bar (11,603 psi)
Magnet movement velocity	Any

Design / Material

Sensor electronics housing ⁹ with flange	GB-J / GB-K / GB-S: Stainless steel 1.4305 (AISI 303), GB-N: Stainless steel 1.4404 (AISI 316L)
Sensor rod	GB-J: Stainless steel 1.4301 (AISI 304), GB-K / GB-S: Stainless steel 1.4306; 1.4307 (AISI 304L), GB-N: Stainless steel 1.4404 (AISI 316L)
Stroke length	25...3250 mm (1...128 in.)

Mechanical mounting

Mounting position	Any
Mounting instruction	Please consult the technical drawings on page 7

Electrical connection

Connection type	M12 male connector (5 pin); M16 male connector (6 pin); cable outlet
Operating voltage	+24 VDC (-15 / +20 %)
Ripple	≤ 0.28 V _{pp}
Current consumption	100 mA typical, dependent on stroke length
Dielectric strength	500 VDC (DC ground to machine ground)
Polarity protection	Up to -30 VDC
Overvoltage protection	Up to 36 VDC

^{7/} The internal digital value is transferred via a 16-bit D/A converter into a proportional, analog current or voltage signal

^{8/} With position magnet # 251 416-2

^{9/} For option **H** (-40...+100 °C / -40...+212 °F) an aluminum cover plate is used

8.2 Technical data GB-M / GB-T

Output

Voltage	0...10 VDC and 10...0 VDC (minimum load controller: > 5 kΩ)
Current	4(0)...20 mA or 20...4(0) mA (minimum / maximum load: 0 / 500 Ω)
Programming	Programming of set points using optional accessories
Measured value	Position

Measurement parameters

Resolution	16 bit (minimum 1 μm depending on stroke length) ¹⁰			
Cycle time	Cycle time	0.5 ms	1.0 ms	2.0 ms
	Stroke length	≤ 1200 mm	≤ 2400 mm	> 2400 mm
Linearity ¹¹	≤ ±0.02 % F.S. (minimum ±60 μm) typical			
Repeatability	≤ ±0.005 % F.S. (minimum ±20 μm) typical			

Operating conditions

Operating temperature	-40...+90 °C (-40...+194 °F); option: -40...+100 °C (-40...+212 °F)
Ingress protection	IP67 (correctly fitted); IP68 (for cable outlet)
Shock test	100 g (single shock), IEC standard 60068-2-27
Vibration test	15 g / 10...2000 Hz, IEC standard 60068-2-6 (excluding resonant frequencies)
EMC test	Electromagnetic emission according to EN 61000-6-4
	Electromagnetic immunity according to EN 61000-6-2
	The sensor meets the requirements of the EU directives and is marked with CE
Operating pressure	350 bar (5,076 psi), 700 bar (10,153 psi) peak (at 10 × 1 min)
Magnet movement velocity	Any

Design / Material

Sensor electronics housing ¹² with flange	Stainless steel 1.4305 (AISI 303)
Sensor rod	Stainless steel 1.4306; 1.4307 (AISI 304L)
Stroke length	25...3250 mm (1...128 in.)

Mechanical mounting

Mounting position	Any
Mounting instruction	Please consult the technical drawings on page 9 f

Electrical connection

Connection type	M12 male connector (5 pin); M16 male connector (6 pin); cable outlet
Operating voltage	+24 VDC (-15 / +20 %)
Ripple	≤ 0.28 V _{pp}
Current consumption	100 mA typical, dependent on stroke length
Dielectric strength	500 VDC (DC ground to machine ground)
Polarity protection	Up to -30 VDC
Overvoltage protection	Up to 36 VDC

¹⁰/The internal digital value is transferred via a 16-bit D/A converter into a proportional, analog current or voltage signal

¹¹/With position magnet # 251 416-2

¹²/For option **H** (-40...+100 °C / -40...+212 °F) an aluminum cover plate is used

9. Appendix

Safety Declaration

Dear Customer,

If you return one or several sensors for checking or repair, we need you to sign a safety declaration. The purpose of this declaration is to ensure that the returned items do not contain residues of harmful substances and / or that people handling these items will not be in danger.

MTS Sensors order number: _____ Sensor type(s): _____

Serial number(s): _____ Sensor length(s): _____

The sensor has been in contact with the following materials:

Don't specify chemical formulas.
Please include safety data sheets of the substances, if applicable.

In the event of suspected penetration of substances into the sensor, consult MTS Sensors to determine measures to be taken before shipment.

Short description of malfunction:

Corporate information

Company: _____

Address: _____

Contact partner

Name: _____

Phone: _____

E-Mail: _____

We hereby certify that the measuring equipment has been cleaned and neutralized.
Equipment handling is safe. Personnel exposure to health risks during transport and repair is excluded.

Stamp

Signature

Date

GERMANY

MTS Sensor Technologie GmbH & Co. KG
Auf dem Schüffel 9
58513 Lüdenscheid, Germany
Tel. +49-23 51-95 87 0
Fax. +49-23 51-5 64 91
info.de@mtssensors.com
www.mtssensors.com

USA

MTS Systems Corporation Sensors Division
3001 Sheldon Drive
Cary, N.C. 27513, USA
Tel. +1 919 677-0100
Fax +1 919 677-0200
info.us@mtssensors.com
www.mtssensors.com

UNITED STATES 3001 Sheldon Drive
Temposonics, LLC Cary, N.C. 27513
Americas & APAC Region Phone: +1 919 677-0100
E-mail: info.us@temposonics.com

GERMANY Auf dem Schüffel 9
Temposonics 58513 Lüdenscheid
GmbH & Co. KG Phone: +49 2351 9587-0
EMEA Region & India E-mail: info.de@temposonics.com

ITALY Phone: +39 030 988 3819
Branch Office E-mail: info.it@temposonics.com

FRANCE Phone: +33 6 14 060 728
Branch Office E-mail: info.fr@temposonics.com

UK Phone: +44 79 44 15 03 00
Branch Office E-mail: info.uk@temposonics.com

SCANDINAVIA Phone: + 46 70 29 91 281
Branch Office E-mail: info.sca@temposonics.com

CHINA Phone: +86 21 2415 1000 / 2415 1001
Branch Office E-mail: info.cn@temposonics.com

JAPAN Phone: +81 3 6416 1063
Branch Office E-mail: info.jp@temposonics.com

Document Part Number:
551511 Revision C (EN) 07/2018



temposonics.com